



ovlac



INSTRUCTIONS AND SPARE PARTS

REV: 2014 - 07



LB-LH

OBSERVATIONS

This handbook describes the use, maintenance instructions and spare parts supplied for the indicated plough.

The farming implement known as "plough" is designed to work the soil, linked to a tractor with lift and universal 3-point coupling.

Regular and satisfactory operation together with economic and long lasting use of the implement depends on compliance with the instructions given in this handbook. It is, therefore, advisable to strictly comply with the following instructions in order to prevent faults which could jeopardise the correct and long-lasting operation of the implement.

Compliance with the instructions in this handbook is also important **since the Manufacturer declines all and every responsibility caused by negligence and failure to comply with these instructions.**

The Manufacturer shall, however, remain at the customer's disposal for immediate and thorough assistance together with anything else that may be required in order to ensure the correct operation and maximum efficiency of the implement. The Manufacturer reserves the right to make any modifications and improvements to the implement, as may be considered opportune, without being obliged to immediately inform the user.

CONTENTS

1.- Safety provisions	3
2.- Descriptions and Technical data	5
3.- "VARILABOR"	6
4.- Auto - Reset protection	6
5.- Set to work	7
5.1.- Mouldboards	
5.2.- Hitching to the tractor	
5.3.- Alignment	
5.4.- Front furrow width	
5.5.- Other adjustments	
6.- Ploughing depth	10
7.- Transport and parking	11
8.- Maintenance	12
9.- Optional equipment	13
10.- Spare parts	14

1.- SAFETY PROVISIONS

Thoroughly read all the plough use instructions

The Manufacturer declines all and every responsibility for failure to comply with the safety and accident-preventing rules described herein.

- 1.- Comply with the instructions given by the danger signals exposed in this handbook (Fig.1) and affixed to the plough itself.
- 2.- Operations and adjustments to the implement must always be carried out when the engine is off and the tractor braked.
- 3.- It is absolutely forbidden to carry passengers or animals on the plough
- 4.- It is absolutely forbidden for persons without a driving license, inexpert persons or those in precarious health conditions to drive the tractor with the plough mounted.
- 5.- Strictly comply with all the recommended accident preventing measures described in this handbook.
- 6.- Assembly of an implement on the tractor will shift the weights on the axles.
- 7.- Before starting the tractor and plough, always check that all safety devices guarding transport and use are in perfect conditions.
- 8.- The instructions labels affixed to the plough give useful advice on how to prevent accidents.
- 9.- Always comply with the highway code in force in your country when travelling on public roads.
- 10.- Comply with the maximum permissible weight on the axle of the tractor, the total adjustable weight, transport regulations and the highway code.

- 11.- Always become familiar with the controls and their operation before starting work.
- 12.- Take the utmost care during the plough coupling and release phases.
- 13.- Never ever leave the driving seat whilst the tractor is moving.
- 14.- Remember that the road holding, steering and breaking capacity may be notably influenced by the presence of a mounted implement.
- 15.- It is absolutely forbidden to stand within the operative range of the plough.
- 16.- Before leaving the tractor, lower the mounted plough coupled to the lift unit, stop the engine, engage the hand brake and remove the ignition key from the control panel.
- 17.- The category of the implement coupling pins must correspond to that of the lift coupling.
- 18.- Take care when working close to the lift links. This is a very dangerous area.
- 19.- It is absolutely forbidden to stand between the tractor and the plough, to manoeuvre the outside lift control.
- 20.- Set the control lever of the hydraulic lift to the locked position during road transport with the plough mounted.
- 21.- The spare parts must correspond to the requirements established by the Manufacturer. Use only genuine spare parts.
- 22.- The safety transfers must always be perfectly visible. They must be kept clean and should be replaced if they become illegible. Replacements are available on request from your local dealer.
- 23.- The instruction manual must be kept for as long as the machine lasts.

WARNING

Thoroughly read the manual before starting to work

DANGER

Do not handle the plough when lifted, danger of flattening. Keep safety distance.

DANGER

Damage can be caused by the rotation of the plough. Keep safety distance.

Be prepared in case of emergency

Have near a first aid kit and an extinguisher. Write down the telephone numbers of doctors, ambulances and firemen and keep them near the telephone.

Use suitable clothes

Avoid loose clothes and use suitable equipment of security according to the type of works. The safe handling of the machine requires all the attention of the operator.

Don't put on auricular to listen to the radio during the work with the machine.

Fig. 1

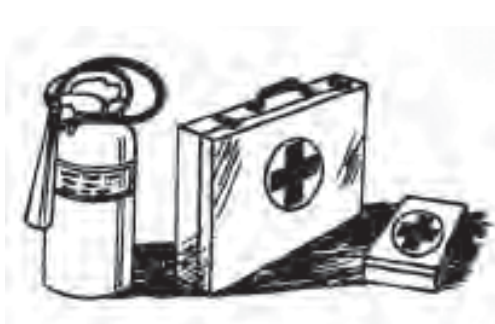

2.- DESCRIPTION

- 1.- Headstock
- 2.- Identification plate
- 3.- Hydraulic Turn
- 4.- Cross shaft
- 5.- Share point
- 6.- Share
- 7.- Shin
- 8.- Mouldboard
- 9.- Depth control wheel
- 10.- Landslide
- 11.- Frame
- 12.- Beam

REMARK: The construction number that is engraved in the identification plate must be coincident with the number engraved on the headstock support.

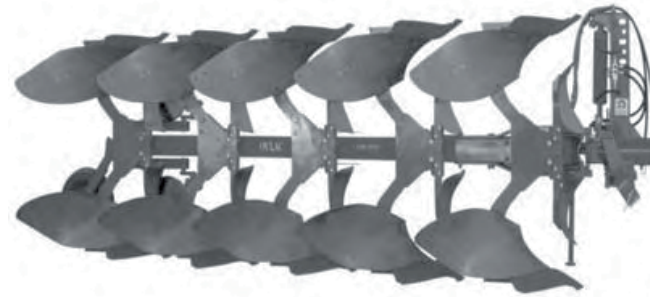

TECHNICAL DATA

N	SB / SH-2	SB/ SH-3	SB / SH-4	SB / SH-5
VARILABOR	12" - 20"			
POWER (CV)	70-90	80-130	100-150	150-200
WEIGHT (KG)	890	1150	1390	1800
CLEARANCE	700mm / 760 mm			

N	DIST.	LB / LH-2	LB / LH-3	LB / LH-4	LB / LH-5
VARILABOR	850 mm	12"-14"-16"-18"			
	950 mm	14"-16"-18"-20"			
POWER (CV)	850 / 950 mm	70-90	80-130	100-150	150-200
WEIGHT (KG)	850 / 950 mm	820	1045	1250	1675
CLEARANCE	850 / 950 mm	700mm / 760 mm			

4.-AUTO-RESET PROTECTION SYSTEMS

3.- VARILABOR

The series "S" (**SB and SH**) incorporates the OVLAC exclusive system to adjust the furrow width -Varilabor- which allows to choose any working width between 12" (35cm) and 20" (50cm) by means of one only operation on the turnbuckle. With the optional hydraulic adjustment, the same operation can be done, even while working, from the tractor cabin, by means of the cylinder.

The indicator, points the chosen furrow width. Varying the furrow width permits to adapt the plough to soil conditions and to the power of the tractor.

In the series "L" (**LB and LH**) the furrow width can be adjusted manually in steps of 2" (5cm) acting on the square. Positions 1 and 4 correspond to the minimum and maximum width respectively.



The Auto Reset protection systems work automatically. When the share meets an obstacle the protection system pulls the beam up (Fig. 2) thus avoiding the obstacle and returning to its original position afterwards with no need to stop the tractor.

This way all the impacts produced by an uneven field are absorbed by the protection system thus protecting all the elements of the plough and of the tractor too.

For the same reason, the Auto Reset protections decreases the traction effort by not making the tractor overcome every eventual obstacle.

- Series "B" (**SB and LB**): In heavy duty conditions one or more leafs cab be added to ease penetration of the plough. Always check that the distance of the arch of the spring is 700 ± 2 mm (Fig 3.)

- Series "H" (**SH and LH**): In order to adapt the plough to soil hardness conditions, in the hydraulic models the release pressure can be adjusted by means of injecting (light soils) or removing (heavy soils) oil from the system. This operation is carried out from the cabin of the tractor by means of the hydraulic tube with manometer supplied to this effect.

Note: The Auto Reset systems from OVLAC are adjusted at the works at an optimal pressure for average conditions.

Make sure that the working pressure is always within the range of 100 and 135 bars.

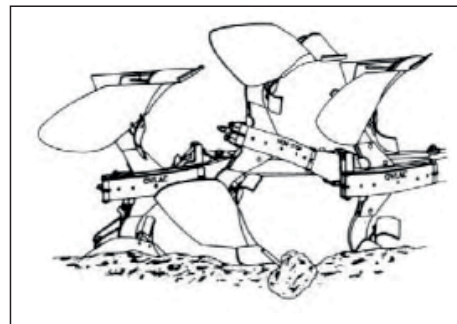

Fig. 2

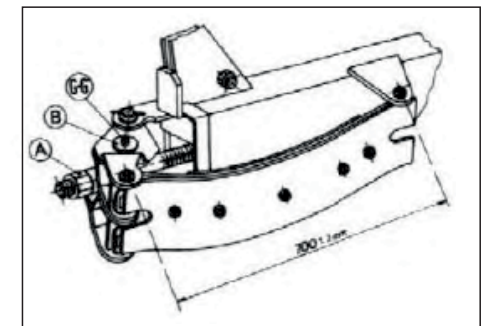

Fig. 3

5.- SET TO WORK

5.1.- MOULDBOARDS

Before starting work, the paint on the mouldboards should be removed to avoid that the soil remains adhered.

Verify that the lengths $A_1=A_2$ and $B_1=B_2$, as shown in fig. 4. If these lengths are not coincident, adjust by means of the stay C, working on the nuts D and D' (Fig.5).

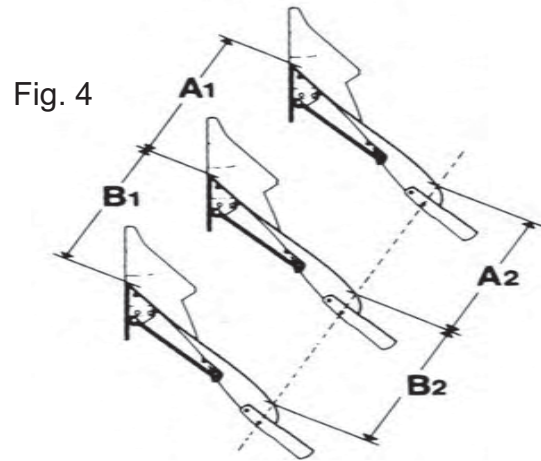
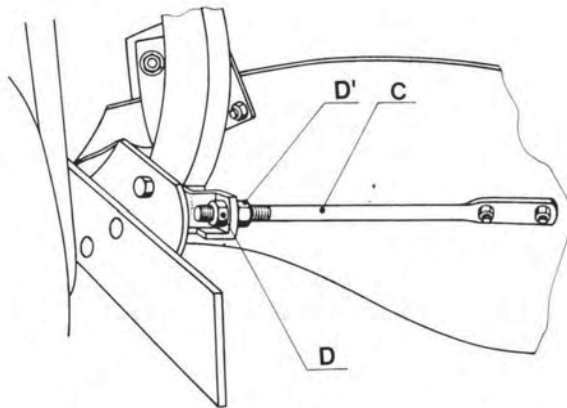

Fig. 5



5.2.- HITCHING TO THE TRACTOR

The OVLAC ploughs are designed to fit to the 3-point universal coupling of any farming tractor.

The cross shaft can be supplied in two different lengths (centre to centre):

Category II 900 mm.

Category III 1.000 mm.

The cross shaft must have the appropriate length to make the drawing powers converge in the centre of the frontal axle, as shown in (Fig. 6).

Fig. 6

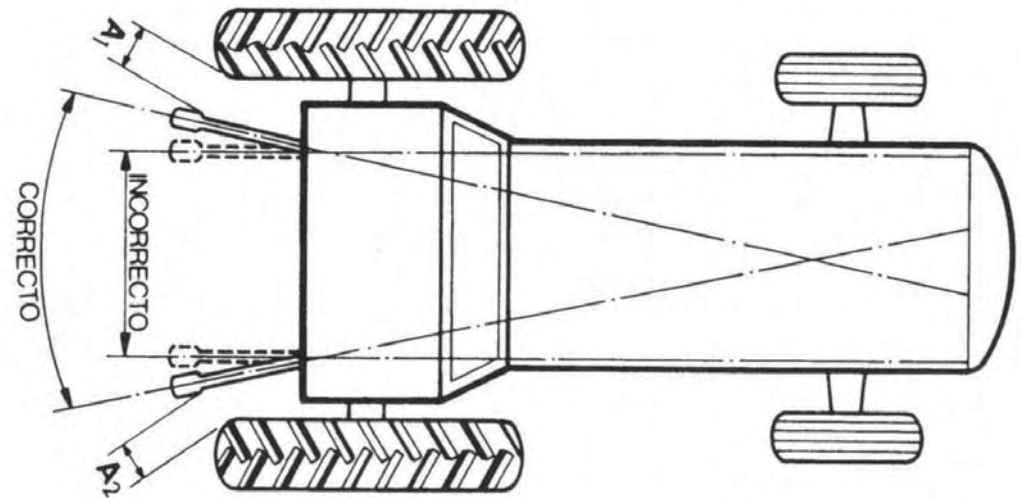

5.3.- ALIGNMENT

The plough should always work in line with the tractor. If not, the tractor will tend to leave the furrow course. Check that lengths $A_1=A_2$ (Fig. 6) Crabbing is corrected automatically in OVLAC ploughs thanks to their oscillating cross shaft. In ploughs with fix coupling, act on the drifting-correction turnbuckle (hydraulic in option). The third point should be linked so that the end linked to the plough be slightly higher than the one linked to the tractor (Fig. 7) The third point should always be placed in the oblong hole E (Fig. 7), trying that its length does not hinder it to move while working.

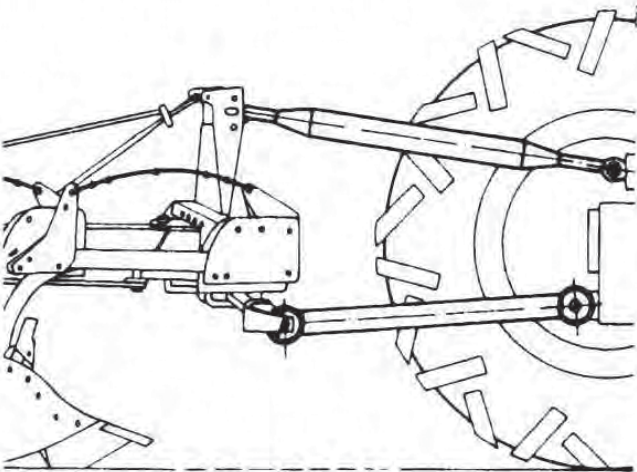
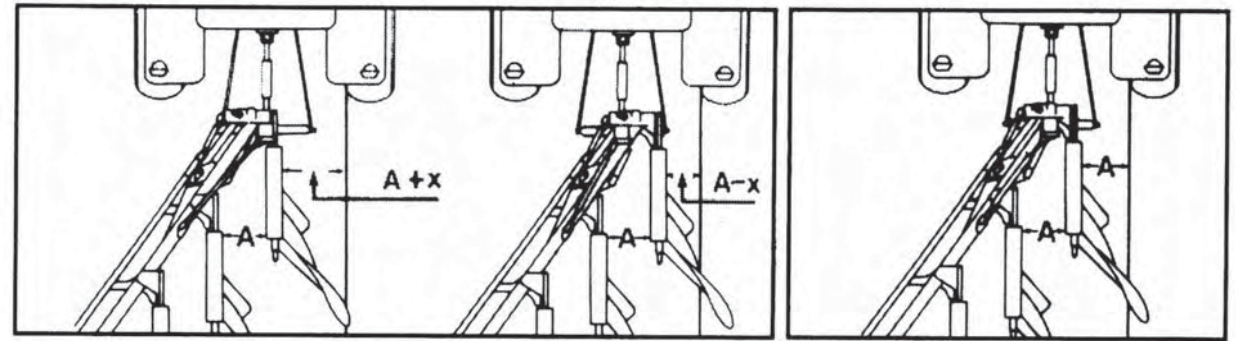

Fig 7

5.4.- FRONT FURROW WIDTH

The width of the first furrow is adjusted by acting on the screw C (Fig. 8) thus moving the headstock laterally until all observations in Fig.9 are complied.



Incorrecto / Wrong / Incorrect

Correcto / Right / Correct

Fig. 9

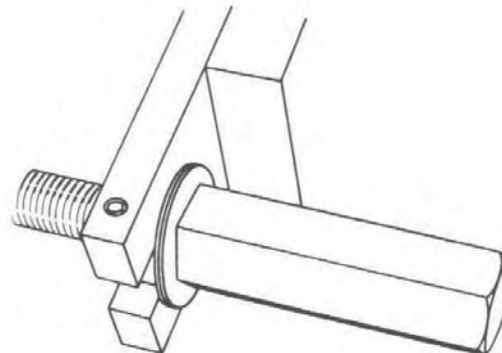
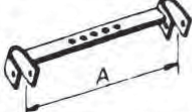
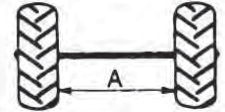

Fig. 8

		Ancho de Surco Furrow Width Largeur Du Sillon
A=82,5	120	30-45
	130	40-50
	140	35-45
	150	40-50
A=93,5	140	35-45
	150	40-50
	160	40-50

5.5 OTHER ADJUSTMENTS

The length of the third point should be adjusted so that the frame works in a parallel position with respect to the field since, if not, the first bodies would plough at a different depth than the rear ones achieving an uneven labour (Fig. 10).

For the same reason, check that the beams work vertically to the field (Fig. 11). To achieve this, make sure that the lifting arms of the tractor are at the same height and act on the adjusting bolts A at the headstock (Fig. 12).

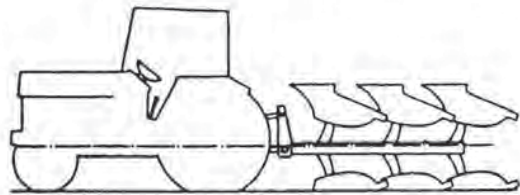

Correcto / Right / Correct

Fig. 10

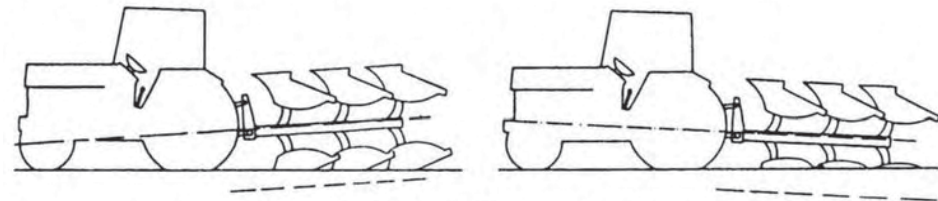

Incorrecto / Wrong / Incorrect

Fig. 11

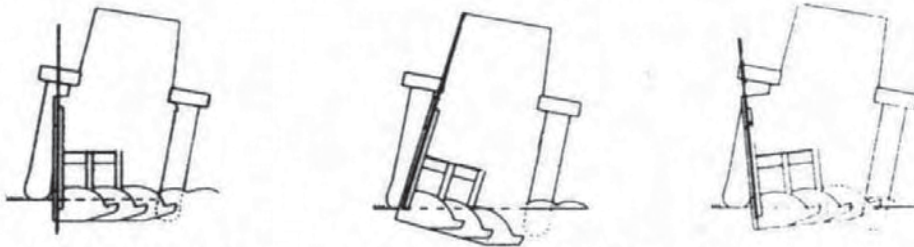

Correcto / Right / Correct

Incorrecto / Wrong / Incorrect

Fig. 12

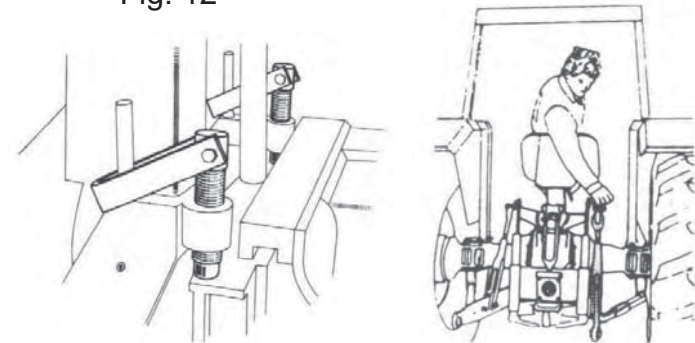

6.- PLOUGHING DEPTH

The ploughing depth is adjusted through the hydraulic lever of the tractor. Nevertheless, obtain an even depth, all ploughs can be equipped with a depth control wheel (Fig.13) whose height is adjusted by the bolts.

There is a relation between depth and width which should be respected in order to achieve a good result.

The following chart gives an excellent reference which , if complied, will lead to satisfactory results.

Width (cm)	30	35	40	45	50
Max. Depth (cm)	24	28	32	36	40
Min. Depth (cm)	15	17	20	22	25
Recommended depth (cm)	21	25	28	32	35



Fig. 13

7.- TRANSPORT AND PARKING

In order to ease transport, the plough should be drawn to its minimum width by means of the width control system (turnbuckle or hydraulic cylinder). Long ploughs (4 and 5 furrows) can be equipped with a multi-purpose wheel: depth control and transport (fig.17).

The stand P (fig.18) guarantees a steady position when the plough is parked. When ploughing the support must be in the position P1.



Fig. 14



Fig. 15

8.- MAINTENANCE

Retighten all bolts and nuts after the first 8 hours of work, specially the ones of mouldboards, shares and points. Henceforth, check every 100 hours of work. When putting the plough away, clean and grease thoroughly the mouldboards to prevent from rusting.

Lubrication: grease the greaser.

Safe maintenance

Be used to the maintenance procedures before carrying out the works. The working zone must be clean and dry. Don't carry out any work of lubrication, repair or adjust with the motor enabled. Keep the hands, feet and clothes always far from movable components. Turn all the controls off, to alleviate the pressure. All the components must be in good state and correctly installed. Repair damages immediately. Change any worn away or broken pieces. Maintain all the components of the machine clean of fat, oil and accumulated dirt. Because of being dragged equipment, disconnect the cable groups of the tractor before making works of weld in the machine.



Take care of the leaks of high pressure

The fluids that escape of the system can have as much force that they can penetrate the skin, causing serious injuries. Therefore, it is essential to leave the system without pressure before relaxing or disconnecting any pipe and make sure that all the connections and the hydraulic parts they are well tight before applying pressure to the system. In order to locate a hydraulic oil leak, use a piece of cardboard that is put on the connections. Do not approach the hands and the body to a leak of high pressure. If, in spite of this precaution, it happens an accident, go immediately to a doctor who should eliminate surgically the fluid within few hours to avoid gangrene. The doctors who do not have experience in dealing with these type injuries can go to a specialized medical centre.

Storage of the hydraulic sleeves.

IMPORTANT: maintain the plugs clean. The abrasive particles, like the sand or the metallic shaving, can damage the oil seals, shirts and cylinders, causing internal leaks. Once disconnected of the tractor, make sure that they are not in contact with the ground.



9.- OPTIONAL EQUIPMENT

Our ploughs can be equipped with (Fig.16)

- A.- Cover boards
- B.- Grass skimmers
- C.- Maize skimmers
- D.- Disc coulters

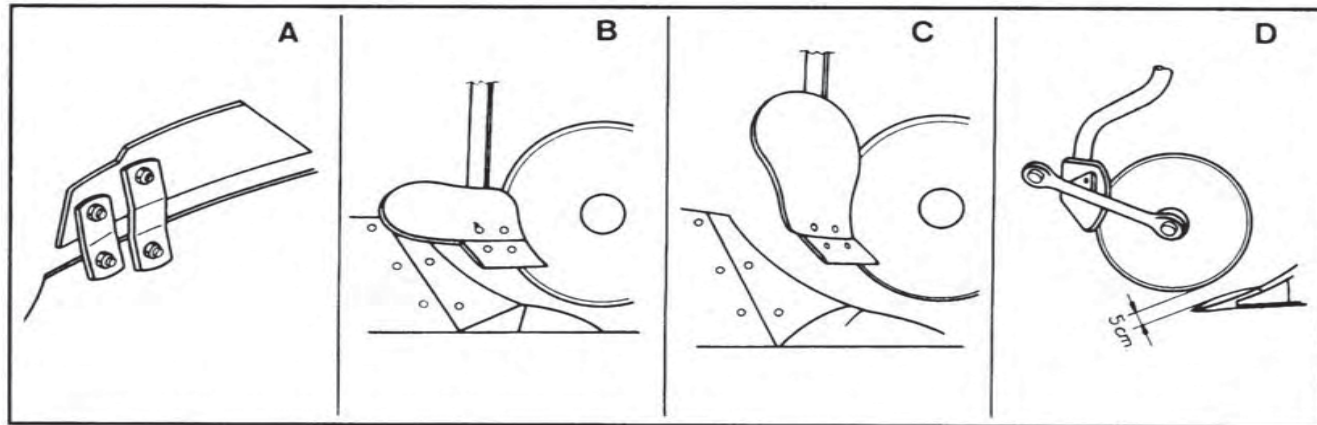

Fig. 16

10.- SPARE PARTS

Spare parts should always be ordered from your dealer and should always include the following indications:

- **Type, model and serial number of the plough.**

These data are punched on the identification plate with which every plough is equipped.

- **Code number of the required spare part.** This will be found in the attached spare parts list.

- **Description of the part and required quantity.**

- **Means of delivery.** Transport expenses shall always be at the consignor's charge.

- **NOTE:** The terms **Right** and **Left** indicated on the descriptions, refer to the plough when viewed from the rear. The spare parts components of waste equipment, as shares, mouldboards, etc., are considered right if they are mounted on a body which spills the soil to the right side and viceversa.

- **Note about the warranty:** The orders of spare parts in warranty should always be clearly specified. **The Manufacturer will always sentence if the spare parts are warranted in their replacement**

- **Moreover, the warranty is suppressed if**

- **The plough is repaired without authorisation from the Manufacturer, or spurious spare parts, and inadequate bolts are mounted.**

- **The plough has been used beyond the specific power limit, or anomalous manoeuvres and operations have been made.**

CONTENTS

1.	HEADSTOCK	15
2.	ROLLOVER AND WIDTH.....	21
3.	MEMORY.....	25
4.	FRAMES	29
5.	FRAME SUPPORT.....	36
6	ADDITIONAL BODY.....	42
7.	BEAM SUPPORT	43
8.	BODIES	44
9.	SKIMMERS.....	50
10.	TRASH BOARDS	52
11.	DISC COULTERS.....	54
12.	WHEELS AND LOCK.....	58

HEADSTOCK 120

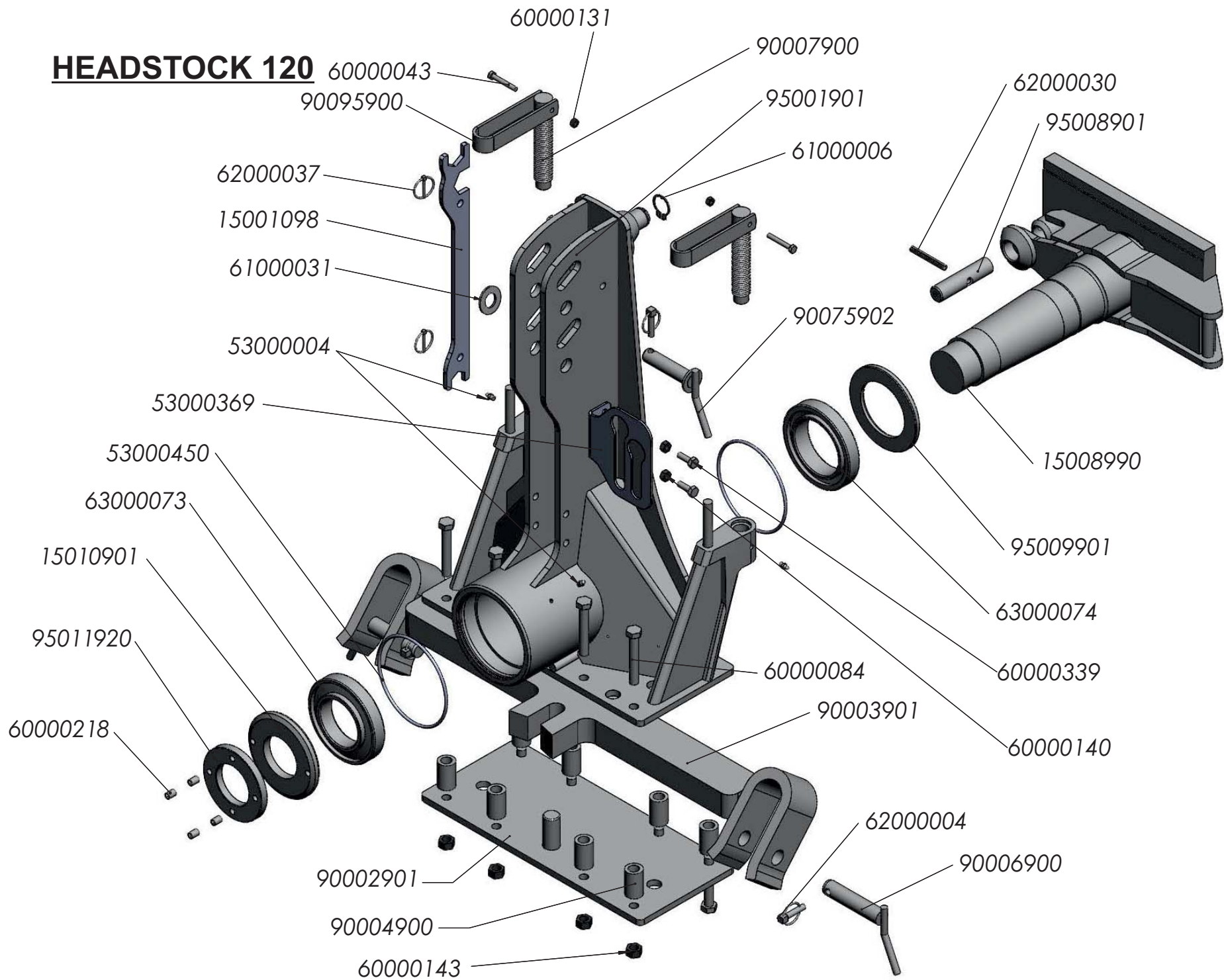

HEADSTOCK 120

Reference	Description	Reference	Description
15001098	KEY 32-38	62000004	RING SPLIT PIN 10 ZINC
15008990	HEADSTOCK SHAFT 120 (D/06)	62000030	ELASTIC PIN D-1481 10*80 ZINC
15010901	HEADSTOCK 120 AXLE NUT (D/06)	62000037	RING SPLIT 4,5 ZINC
53000004	GREASER MT-503 8*125 D-71412	63000073	FRONT BEARING 30218 F
53000369	HYDR. PIPES BRACEKT HEADSTOCK 2 HOLLOW Z. ZINC	63000074	REAR BEARING 32021 XF
53000450	O-RING 160-3	90003901	CROSS SHAFT 50mm CAT-II
60000043	BOLT D-931 8*55 8.8 ZINC	90006900	SHAFT PIN D=28*130 mm CAT II ZINC
60000084	BOLT D-931 16*100 8.8	90006905	CROSS SHAFT PIN D=36/28*140 mm CAT.III
60000131	SELF LOCKING NUT D-980 8 8.8 ZINC	90007900	STOP TURNBUCKLE 185 mm
60000140	SELF LOCK. NUT D-980 10 8.8 ZINC	90075902	PIN D=25*110 mm 3RD POINT CAT II ZINC
60000143	SELF LOCK NUT D-980 16 8.8 ZINC	90095900	STOP BRACELET ZINC
60000218	ALLEN BOLT D-913 12*16 12.9	95001901	HEADSTOCK 120 (D/04)
60000339	BOLT D-933 10*30 8.8 ZINC	95008901	LOWER PIN D= 29,6*123 mm ROLLOVER CYLIND. 110/120
61000006	ELASTIC RING D-471 35	95009901	REAR WASHER 120 (D/03)
61000031	WASHER 26 ZINC	95011920	HEADSTOCK 110/120/150 SHAFT NET LOCK

HEADSTOCK 130

A, A' y A'' (Corners):
- A (Bolt): REF: 60000474
- A' (Nut): REF: 60000146
- A'' (Bush): REF: 90004906

B, B' y B'' (Others):
- B (Bolt): REF: 60000084
- B' (Nut): REF: 60000143
- B'' (Spacer): REF: 90004900

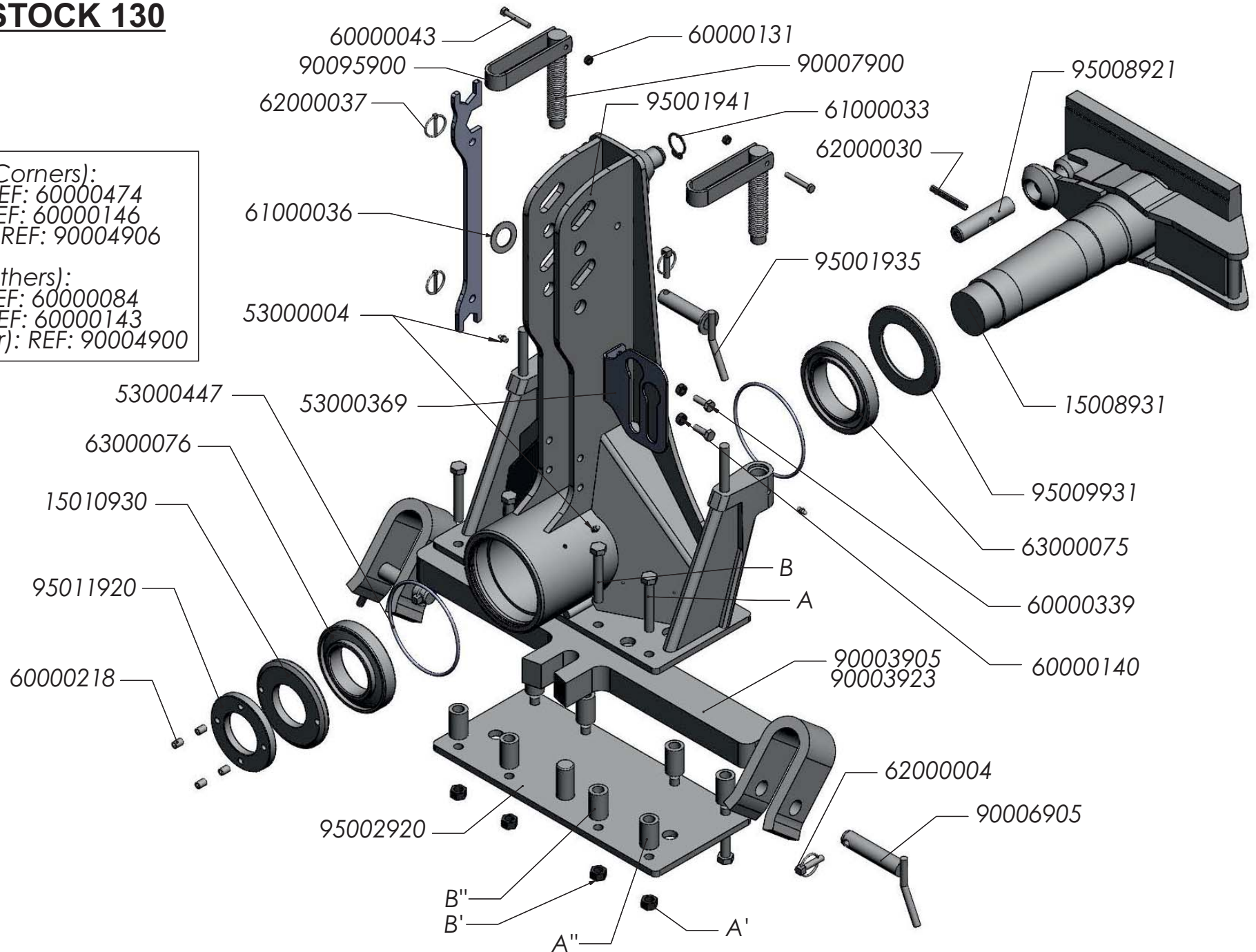

HEADSTOCK 130

Reference	Description	Reference	Description
15001098	KEY 32-38	62000030	ELASTIC PIN D-1481 10*80 ZINC
15008931	HEADSTOCK SHAFT 150 (D/06)	62000037	RING SPLIT 4,5 ZINC
15010930	HEADSTOCK AXLE 150 NUT (D/06)	63000075	REAR BEARING 32026 F
53000004	GREASER MT-503 8*125 D-71412	63000076	FRONT BEARING 30222 F
53000369	HYDR. PIPES BRACEKT HEADSTOCK 2 HOLLOW Z. ZINC	90003905	CROSS SHAFT 50mm 5-FU.CAT-II/III
53000447	O-RING 200-3 NBR	90003923	CROSS SHAFT 50mm 5-FU CAT-III
60000043	BOLT D-931 8*55 8.8 ZINC	90004900	SPACER B.P. 32/20*52 mm
60000084	BOLT D-931 16*100 8.8	90004906	SPACER CROSS SHAFT BUSH D=45/20,5*52 mm
60000131	SELF LOCKING NUT D-980 8 8.8 ZINC	90006905	CROSS SHAFT PIN D=36/28*140 mm CAT.III
60000140	SELF LOCK. NUT D-980 10 8.8 ZINC	90007900	STOP TURNBUCKLE 185 mm
60000143	SELF LOCK NUT D-980 16 8.8 ZINC	90095900	STOP BRACELET ZINC
60000146	SELF LOCK NUT D-980 20 10.9 ZINC	95001935	PIN D=31,2*115 mm 3RD POINT CAT.III
60000218	ALLEN BOLT D-913 12*16 12.9	95001941	HEADSTOCK 150-L
60000339	BOLT D-933 10*30 8.8 ZINC	95002920	SHAFT PLATE 50 mm
60000474	BOLT D-931 20*110 12.9	95008921	LOWER PIN D=34,6*150 mm ROLLOVER CYLIND. 150
61000033	ELASTIC RING D-471 40	95009931	REAR WASHER 110 (D/07)
61000036	WASHER 32 ZINC	95011920	HEADSTOCK 110/120/150 SHAFT NET LOCK
62000004	RING SPLIT PIN 10 ZINC		

HEADSTOCK 150 - 180

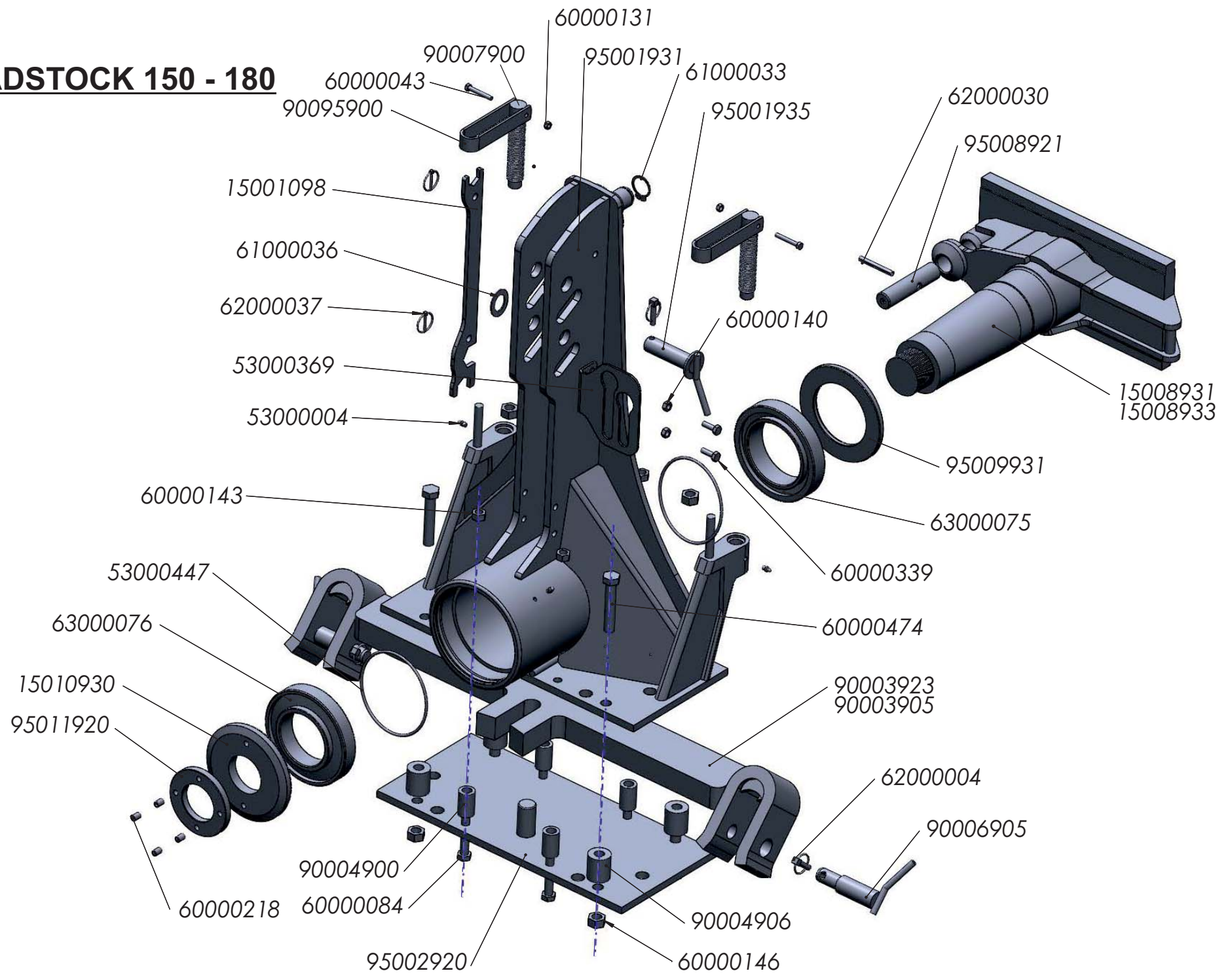

HEADSTOCK 150 - 180

Reference	Description	Reference	Description
15001098	KEY 32-38	62000030	ELASTIC PIN D-1481 10*80 ZINC
15008931	HEADSTOCK SHAFT 150 (D/06)	62000037	RING SPLIT 4,5 ZINC
15010930	HEADSTOCK AXLE 150 NUT (D/06)	63000075	REAR BEARING 32026 F
53000004	GREASER MT-503 8*125 D-71412	63000076	FRONT BEARING 30222 F
53000369	HYDR. PIPES BRACEKT HEADSTOCK 2 HOLLOW Z. ZINC	90003905	CROSS SHAFT 50mm 5-FU.CAT-II/III
53000447	O-RING 200-3 NBR	90003923	CROSS SHAFT 50mm 5-FU CAT-III
60000043	BOLT D-931 8*55 8.8 ZINC	90004900	SPACER B.P. 32/20*52 mm
60000084	BOLT D-931 16*100 8.8	90004906	SPACER CROSS SHAFT BUSH D=45/20,5*52 mm
60000131	SELF LOCKING NUT D-980 8 8.8 ZINC	90006905	CROSS SHAFT PIN D=36/28*140 mm CAT.III
60000140	SELF LOCK. NUT D-980 10 8.8 ZINC	90007900	STOP TURNBUCKLE 185 mm
60000143	SELF LOCK NUT D-980 16 8.8 ZINC	90095900	STOP BRACELET ZINC
60000146	SELF LOCK NUT D-980 20 10.9 ZINC	95001931	HEADSTOCK 150 (D/04)
60000218	ALLEN BOLT D-913 12*16 12.9	95001935	PIN D=31,2*115 mm 3RD POINT CAT.III
60000339	BOLT D-933 10*30 8.8 ZINC	95002920	SHAFT PLATE 50 mm
60000474	BOLT D-931 20*110 12.9	95008921	LOWER PIN D=34,6*150 mm ROLLOVER CYLIND. 150
61000033	ELASTIC RING D-471 40	95009931	REAR WASHER 110 (D/07)
61000036	WASHER 32 ZINC	95011920	HEADSTOCK 110/120/150 SHAFT NET LOCK
62000004	RING SPLIT PIN 10 ZINC		

ROLLOVER 120

Reference	Description
51000076	ROLLOVER CYL. 35/63/260 W/VALVE
53000006	GASKET 1/2" 11603
53000007	GASKET 3/8" 11602
53000015	MALE JOINT 3/8" 4062
53000021	PLUG RED CAP 1/2"
53000451	ANGLE 45° W/NUT 3/8 S952-17
53000457	HYDR. TUBE 1/4*1500 mm MF-1/2; TL-3/8
55000003	MALE FAST COUPLING 1/2" 30410108

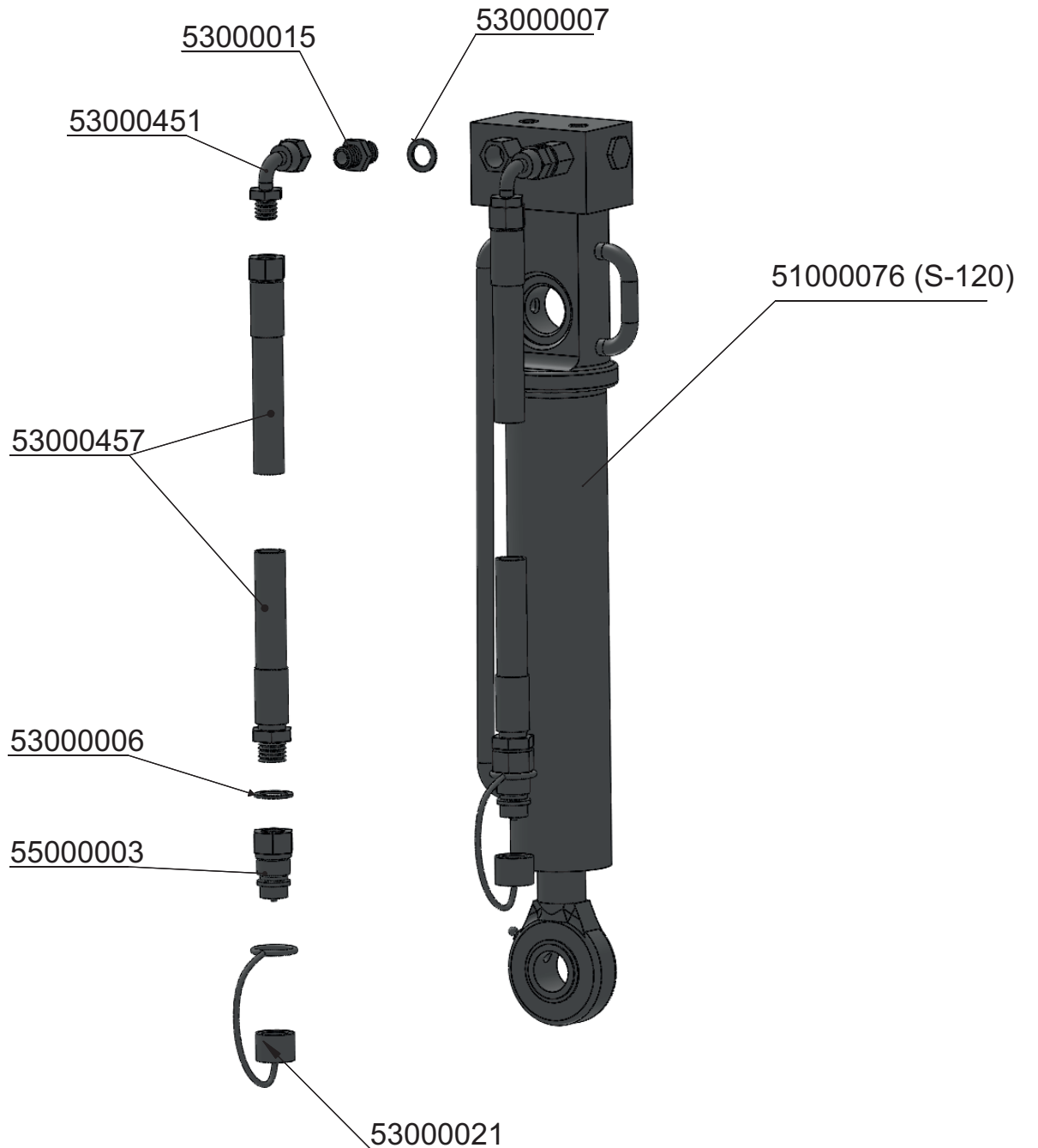

ROLLOVER 130 - 150 - 180

Reference	Description
51000078	ROLLOVER CYL. 40/90/300 SEC/VALVE
51000184	ROLLOVER CYL. 35/63/260 S/VALVE
53000006	GASKET 1/2" 11603
53000007	GASKET 3/8" 11602
53000015	MALE JOINT 3/8" 4062
53000021	PLUG RED CAP 1/2"
53000093	GASKET 1/4 11601
53000371	MALE CAP 1/4 S830-13
53000451	ANGLE 45° W/NUT 3/8 S952-17
53000457	HYDR. TUBE 1/4*1500 mm MF-1/2; TL-3/8
55000003	MALE FAST COUPLING 1/2" 30410108

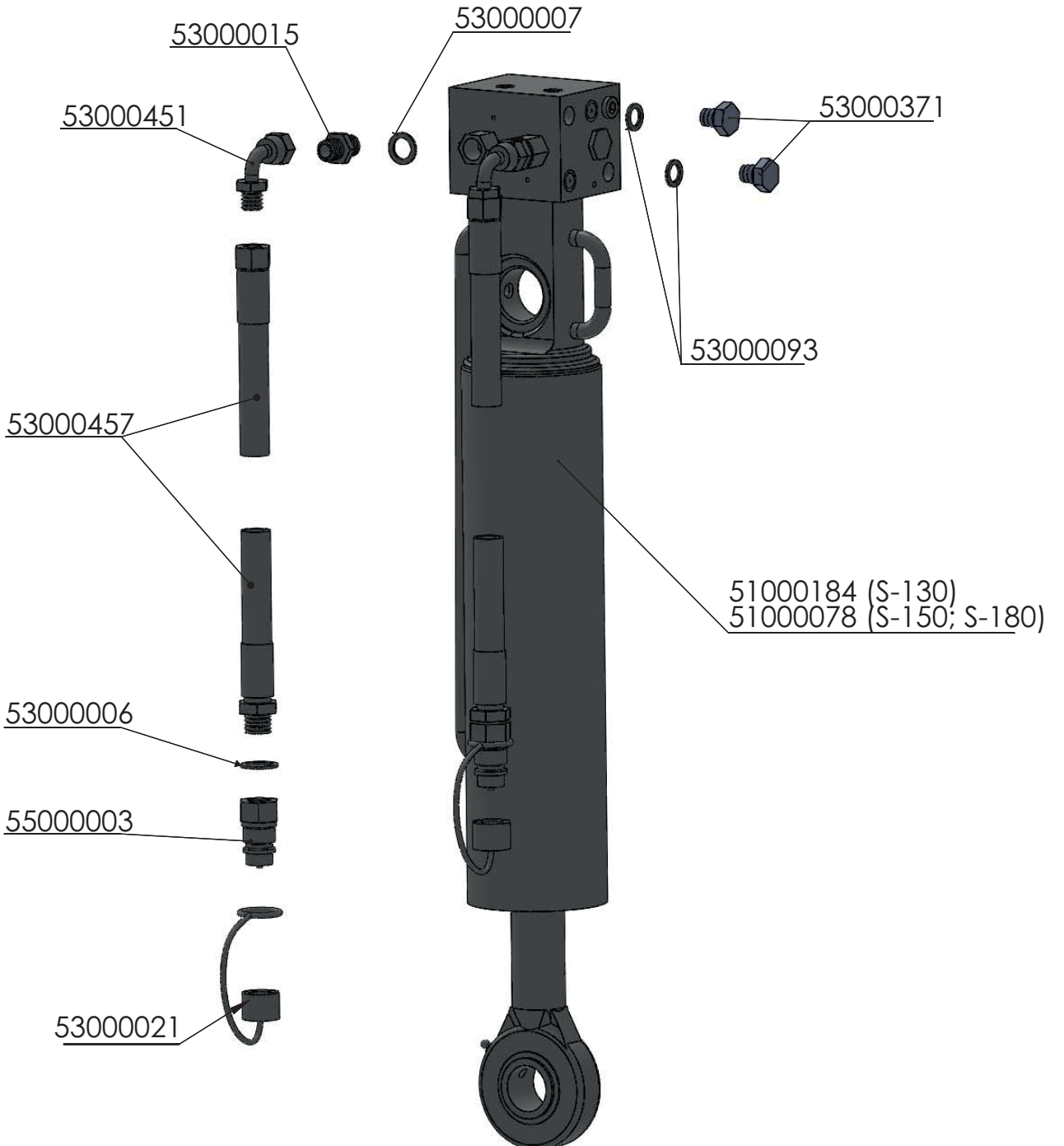

VARYWIDTH SYSTEM

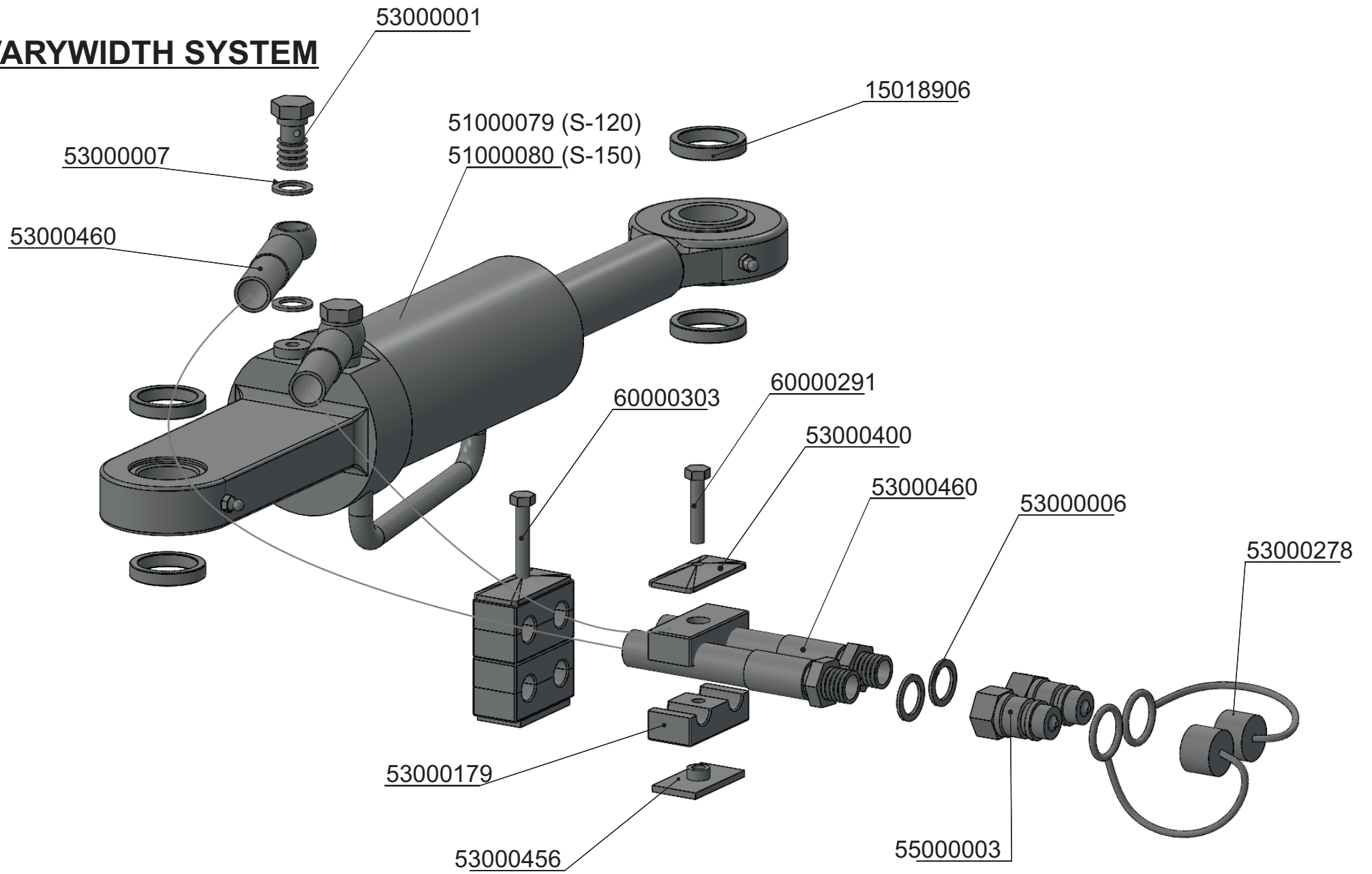

VARYWIDTH SYSTEM

Reference	Description
15018906	WIDTH SPACER D=45/35*8 mm
51000079	WIDTH HYDR. CYLINDER 40/80/100
51000080	WIDTH HYDR. CYLINDER 42/100/100
53000001	BOLT 3/8 4022
53000006	GASKET 1/2" 11603
53000007	GASKET 3/8" 11602
53000179	DOUBLE U-BOLT D=15mm
53000278	PLUG YELLOW CAP 1/2" 5029
53000400	REINFORCEMENT PLATE 15/18
53000456	PLATE 15/18 SP2D
53000460	HYDR.TUBE MF210-1/4*3550 mm MF-1/2; OR-3/8
55000003	MALE FAST COUPLING 1/2" 30410108
60000291	BOLT D-931/933 8*40 8.8 ZINC
60000303	BOLT D-931 8*65 8.8 ZINC

MEMORIE 120 - 130 - 150

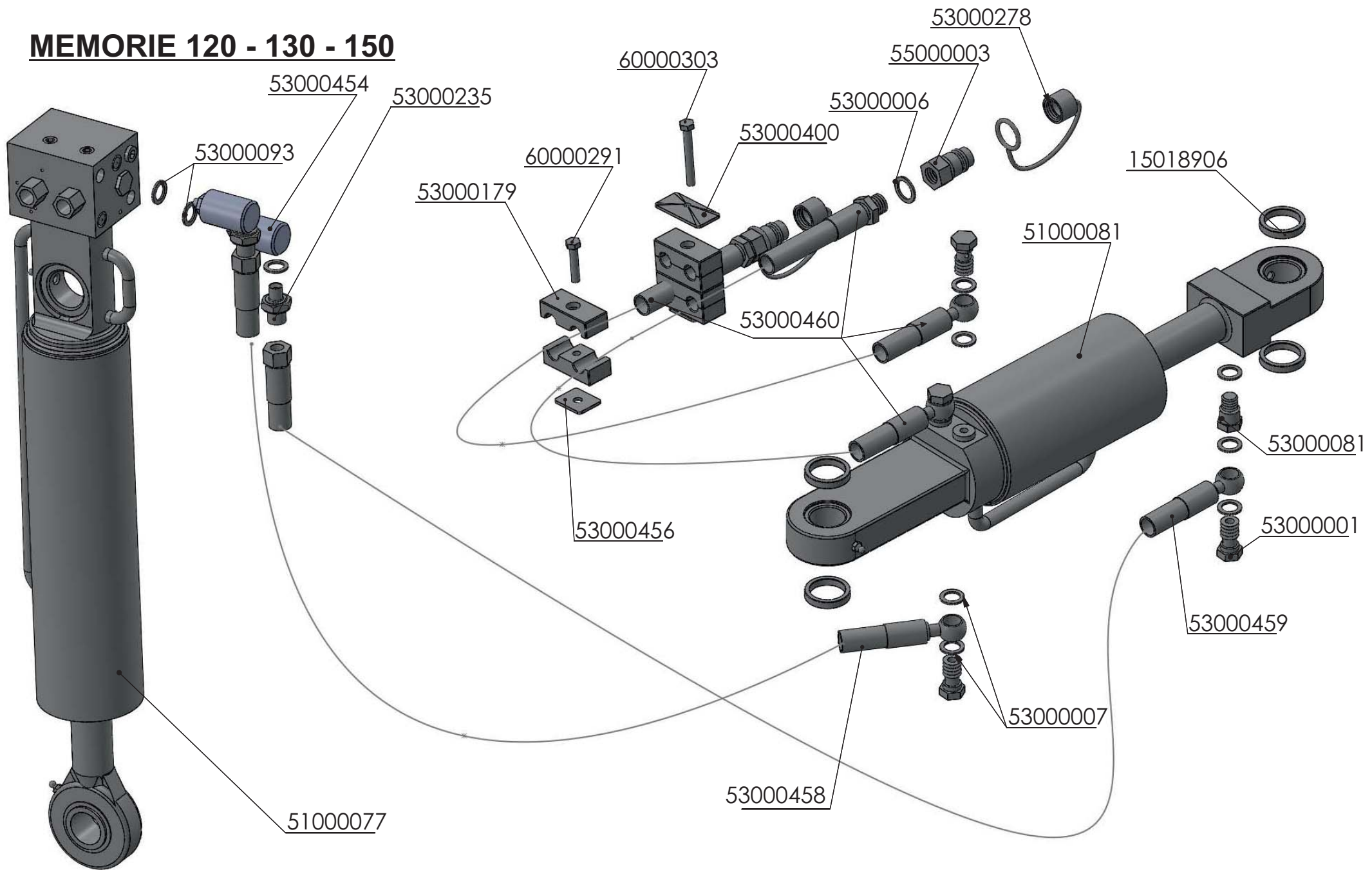

MEMORIE 120 - 130 - 150

Reference	Description
15018906	WIDTH SPACER D=45/35*8 mm
51000077	ROLLOVER CYL. 35/63/260 SEC/VALVE
51000081	MEMORY CYLINDER 42/100/100
53000001	BOLT 3/8 4022
53000006	GASKET 1/2" 11603
53000007	GASKET 3/8" 11602
53000081	ENLARGEMENT 3/8" 4092
53000093	GASKET 1/4 11601
53000179	DOUBLE U-BOLT D=15mm
53000235	REDUCTION JOINT 1/4-3/8 4071
53000278	PLUG YELLOW CAP 1/2" 5029
53000400	REINFORCEMENT PLATE 15/18
53000454	SWIVEL FITTING 90° 1-WAY 1/4 G0990
53000456	PLATE 15/18 SP2D
53000458	HYDR.TUBE MF210-1/4*2010 mm OR-3/8; TL-3/8
53000459	HYDR.TUBE MF210-1/4*2580 mm OR-3/8; TL-3/8
53000460	HYDR.TUBE MF210-1/4*3550 mm MF-1/2; OR-3/8
55000003	MALE FAST COUPLING 1/2" 30410108
60000291	BOLT D-931/933 8*40 8.8 ZINC
60000303	BOLT D-931 8*65 8.8 ZINC

MEMORIE 180

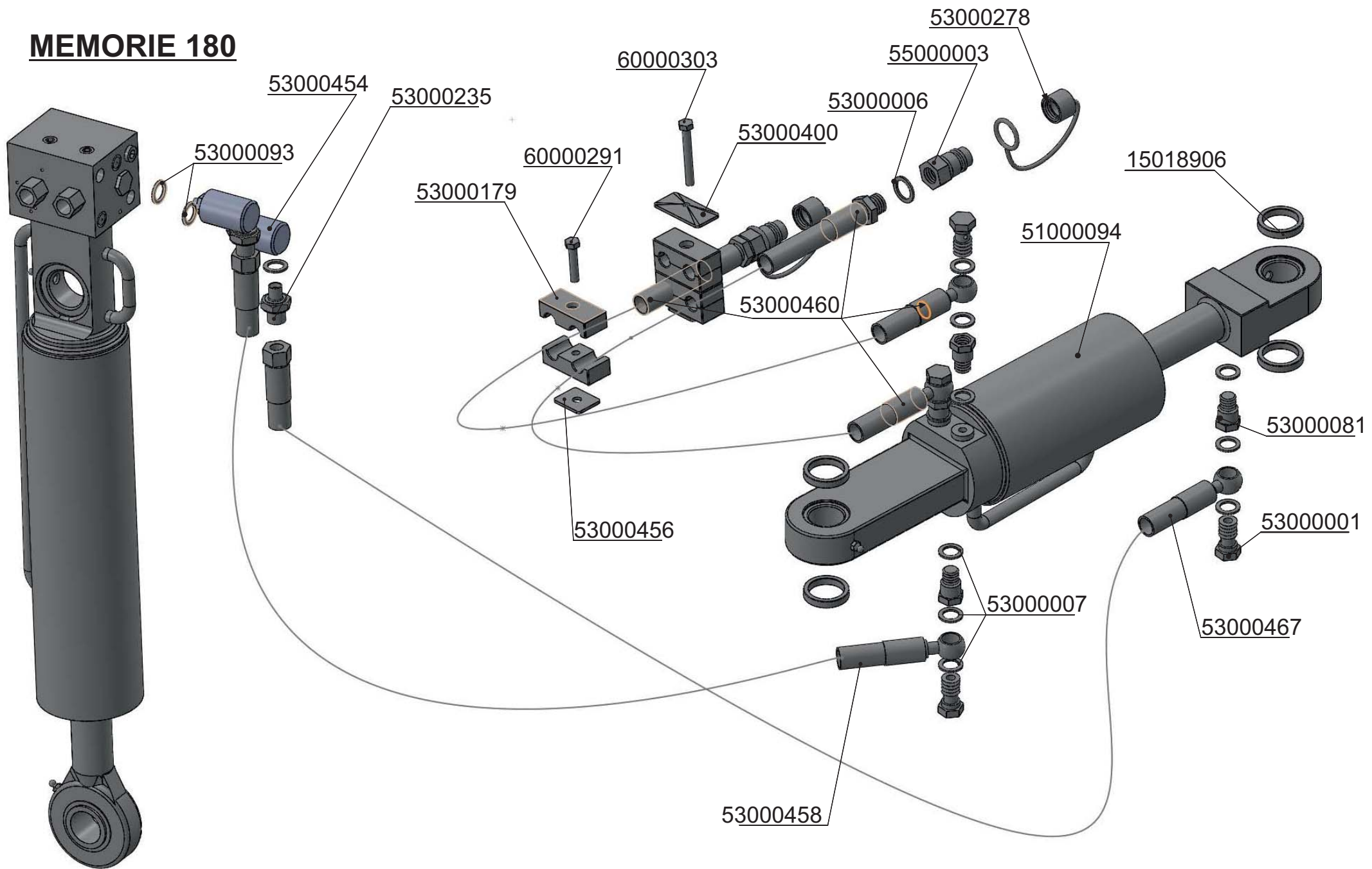

MEMORIE 180

Reference	Description
15018906	WIDTH SPACER D=45/35*8 mm
51000094	MEMORY CYLINDER 42/100/145
53000001	BOLT 3/8 4022
53000006	GASKET 1/2" 11603
53000007	GASKET 3/8" 11602
53000081	ENLARGEMENT 3/8" 4092
53000093	GASKET 1/4 11601
53000179	DOUBLE U-BOLT D=15mm
53000235	REDUCTION JOINT 1/4-3/8 4071
53000278	PLUG YELLOW CAP 1/2" 5029
53000400	REINFORCEMENT PLATE 15/18
53000454	SWIVEL FITTING 90° 1-WAY 1/4 G0990
53000456	PLATE 15/18 SP2D
53000458	HYDR.TUBE MF210-1/4*2010 mm OR-3/8; TL-3/8
53000459	HYDR.TUBE MF210-1/4*2580 mm OR-3/8; TL-3/8
53000460	HYDR.TUBE MF210-1/4*3550 mm MF-1/2; OR-3/8
55000003	MALE FAST COUPLING 1/2" 30410108
60000291	BOLT D-931/933 8*40 8.8 ZINC
60000303	BOLT D-931 8*65 8.8 ZINC

FRAME LB - LH

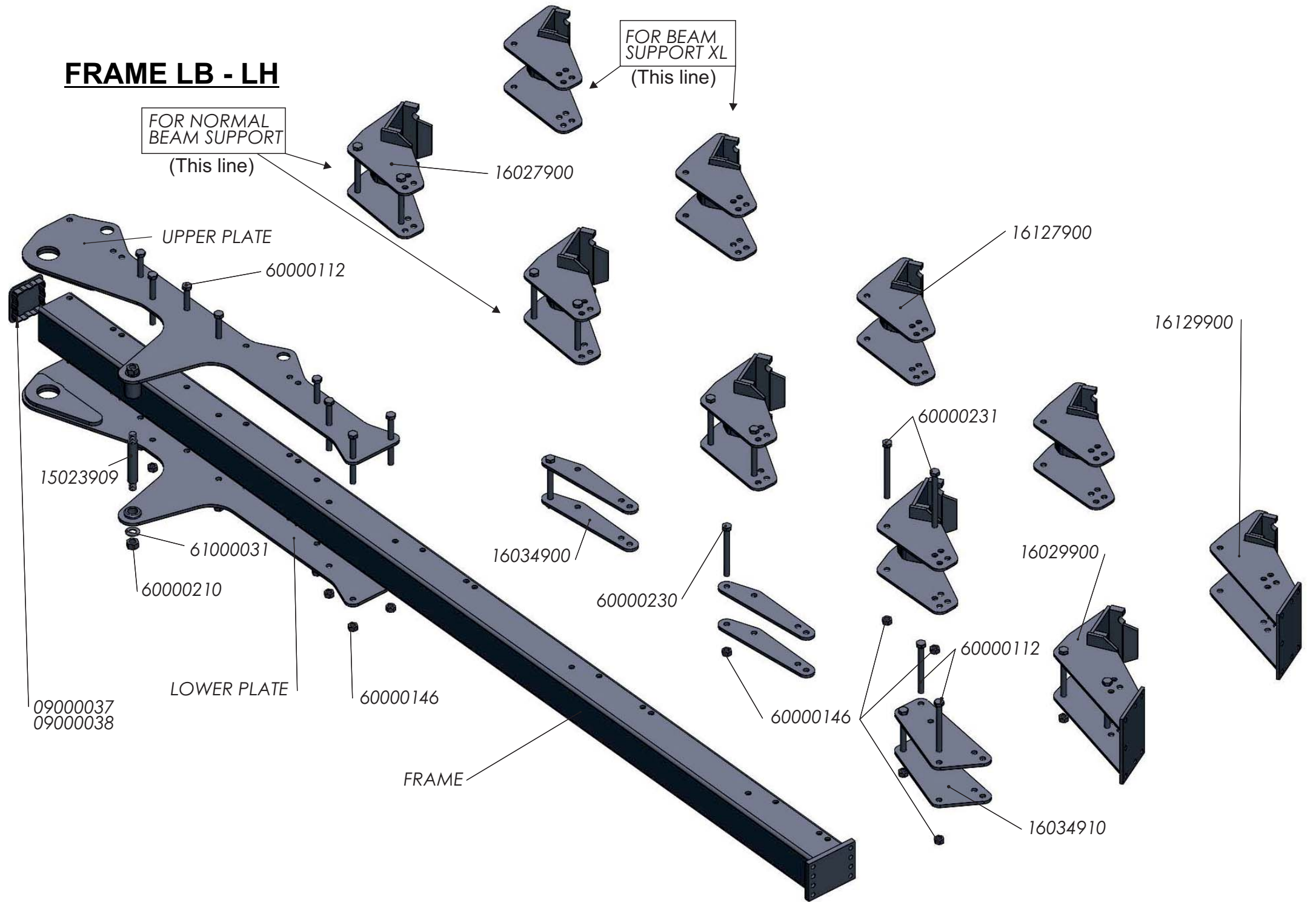

FRAME LB - LH

Reference	Description
9000037	RUBBER CAP 150*100*10 mm
9000038	RUBBER CAP 150*150*10 mm
15023909	TURNBUCKLE REAR PIN SN D=34,6*240 mm
16027900	BEAM BRACKET LBN
16029900	BEAM/WHEEL BRACKET LBN
16034900	LEAN PLATE BRACKETS L
16034910	LEAN PLATE BRACKETS TRANSP.WHEEL L
16127900	BEAM BRACKET LBN-L
16129900	BEAM/WHEEL BRACKET LBN-L
60000112	BOLT D-931 20*200 8.8
60000146	SELF LOCK NUT D-980 20 10.9 ZINC
60000210	SELF LOCK NUT D-985 1" SAE 8.8
60000230	BOLT 20*200 12.9
60000231	BOLT 20*225 12.9
61000031	WASHER 26 ZINC

UPPER PLATE		LOWER PLATE	
Reference	Description	Reference	Description
15023903	UPPER PLATE FRAME TURN SUPPORT SN-2-95	15023953	LOWER PLATE FRAME TURN SUPPORT SN-2-95
15023904	UPPER PLATE FRAME TURN SUPPORT SN-3/4-95	15023954	LOWER PLATE FRAME TURN SUPPORT SN-3/4-95
15023905	UPPER PLATE FRAME TURN SUPPORT SN-4A/5-95	15023955	LOWER PLATE FRAME TURN SUPPORT SN-4A/5-95
15023906	UPPER PLATE FRAME TURN SUPPORT SN-5A/6-95	15023956	LOWER PLATE FRAME TURN SUPPORT SN-5A/6-95
15023913	UPPER PLATE FRAME TURN SUPPORT SN-2-85	15023963	LOWER PLATE FRAME TURN SUPPORT SN-2-85
15023914	UPPER PLATE FRAME TURN SUPPORT SN-3/4-85	15023964	LOWER PLATE FRAME TURN SUPPORT SN-3/4-85
15023915	UPPER PLATE FRAME TURN SUPPORT SN-4A/5-85	15023965	LOWER PLATE FRAME TURN SUPPORT SN-4A/5-85
15023916	UPPER PLATE FRAME TURN SUPPORT SN-5A/6-85	15023966	LOWER PLATE FRAME TURN SUPPORT SN-5A/6-85
15023923	UPPER PLATE FRAME TURN SUPPORT SN-2-105	15023973	LOWER PLATE FRAME TURN SUPPORT SN-2-105
15023924	UPPER PLATE FRAME TURN SUPPORT SN-3/4-105	15023974	LOWER PLATE FRAME TURN SUPPORT SN-3/4-105
15023925	UPPER PLATE FRAME TURN SUPPORT SN-4A/5-105	15023975	LOWER PLATE FRAME TURN SUPPORT SN-4A/5-105

FRAME LB - LH

FRAME			
LB		LH	
Reference	Description	Reference	Description
15019902	FRAME SN-2-95	16019902	FRAME SHN-2-95
15019903	FRAME SN-3-95	16019903	FRAME SHN-3-95
15019904	FRAME SN-4-95	16019904	FRAME SHN-4-95
15019905	FRAME SN-5-95	16019905	FRAME SHN-5-95
15019906	FRAME SN-6-95	16019906	FRAME SHN-6-95
15019912	FRAME SN-2-85	16019912	FRAME SHN-2-85
15019913	FRAME SN-3-85	16019913	FRAME SHN-3-85
15019914	FRAME SN-4-95	16019914	FRAME SHN-4-95
15019915	FRAME SN-5-85	16019915	FRAME SHN-5-85
15019916	FRAME SN-6-85	16019916	FRAME SHN-6-85
15019922	FRAME SN-2-105	16019922	FRAME SHN-2-105
15019925	FRAME SN-5-100	16019925	FRAME SHN-5-105
15019943	FRAME SN-3-105 (100 - NO EXT.)	16019943	FRAME SHN-3-105 (100 - NO EXT.)
15019944	FRAME SN-4-105 (150 - NO EXT.)	16019944	FRAME SHN-4-105 (150 - NO EXT.)
15019953	FRAME SN-3-95 (150)	16019953	FRAME SHN-3-95-(150)
15019954	FRAME SN-4-95-EXT	16019954	FRAME SHN-4-95-EXT
15019955	FRAME SN-5-95-EXT	16019955	FRAME SHN-5-95-EXT
15019963	FRAME SN-3-85 (150)	16019963	FRAME SHN-3-85-(150)
15019964	FRAME SN-4-85-EXT	16019964	FRAME SHN-4-85-EXT
15019965	FRAME SN-5-95 EXT.	16019965	FRAME SHN-5-85-EXT
15019973	FRAME SN-3-105 (150)	16019973	FRAME SHN-3-105-(150)
15019974	FRAME SN-4-105-EXT	16019974	FRAME SHN-4-105-EXT
15019985	FRAME SN-5-85 (100 - NO EXT.)		
28019904	FRAME FBN-4-95		

FRAME SUPPORT 120 - 130

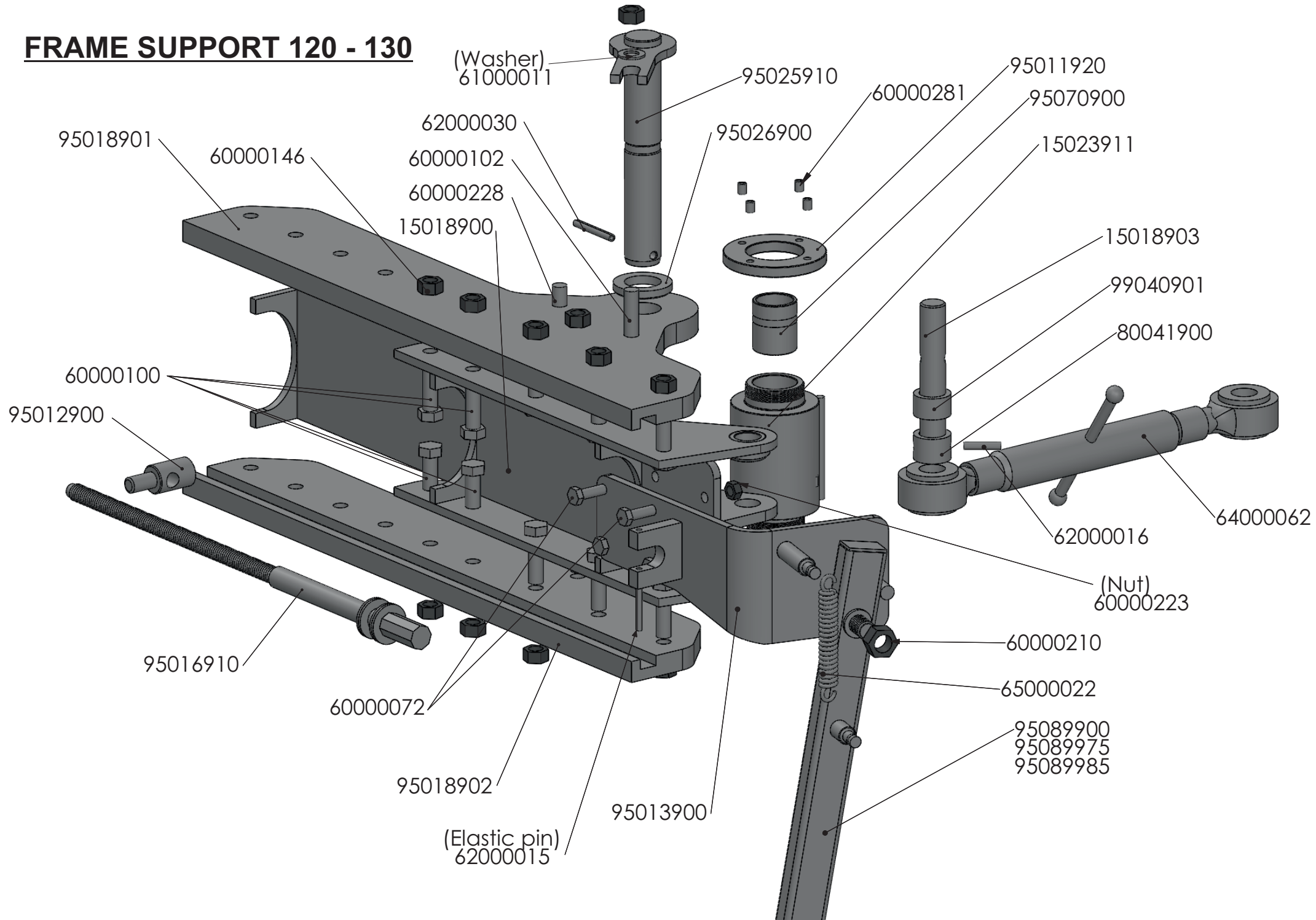

FRAME SUPPORT 120 - 130

Reference	Description	Reference	Description
15018900	FRAME SUPPORT SN-120	64000062	TURNBUCKLE WITH EYE D=35 30386 ZINC
15018903	TURNBUCKLE FRONT PIN D=34,6*215 mm SN	65000022	SPRING 225/175*26*5 195 mm
15023911	FRAME TURNING BUSH SN 120	80041900	SPACER B.P. 51/36*35 mm ZINC
53000004	GREASER MT-503 8*125 D-71412	95011920	HEADSTOCK 110/120/150 SHAFT NET LOCK
60000072	BOLT D-931 14*50 8.8	95012900	FRAME ADJUSTING NUT 120/150
60000100	BOLT D-931 20*70 8.8	95013900	STAND SUPPORT
60000102	BOLT D-931 20*80 8.8	95016910	STOP TURNBUCKLE 500 mm (D/14)
60000146	SELF LOCK NUT D-980 20 10.9 ZINC	95018901	UPPER PLATE FRAME SUPPORT 120
60000210	SELF LOCK NUT D-985 1" SAE 8.8	95018902	LOWER PLATE FRAME SUPPORT 120
60000223	SELF LOCK. NUT D-980 14 8.8 ZINC	95025910	FRAME TURN PIN S (D/03)
60000228	ALLEN BOLT D-7991 20*70 10.9	95026900	WASHER FRAME TURNING
60000281	ALLEN BOLT D-913 12*14 12.9	95070900	LAMINATED BUSH D=60/50*70 mm SS / FRAME TURNING
61000011	WASHER D-125 20	95089900	REV.STAND 70cm, 75 cm SL
62000015	ELASTIC PIN D-1481 8*80 ZINC	95089975	REV.STAND 75cm U.BEAM CLEAR.(P/02)
62000016	ELASTIC PIN D-1481 10*50 ZINC	95089985	REV.STAND 85cm
62000030	ELASTIC PIN D-1481 10*80 ZINC	99040901	SPACER B.P. 51/36*30 mm ZINC

FRAME SUPPORT 150

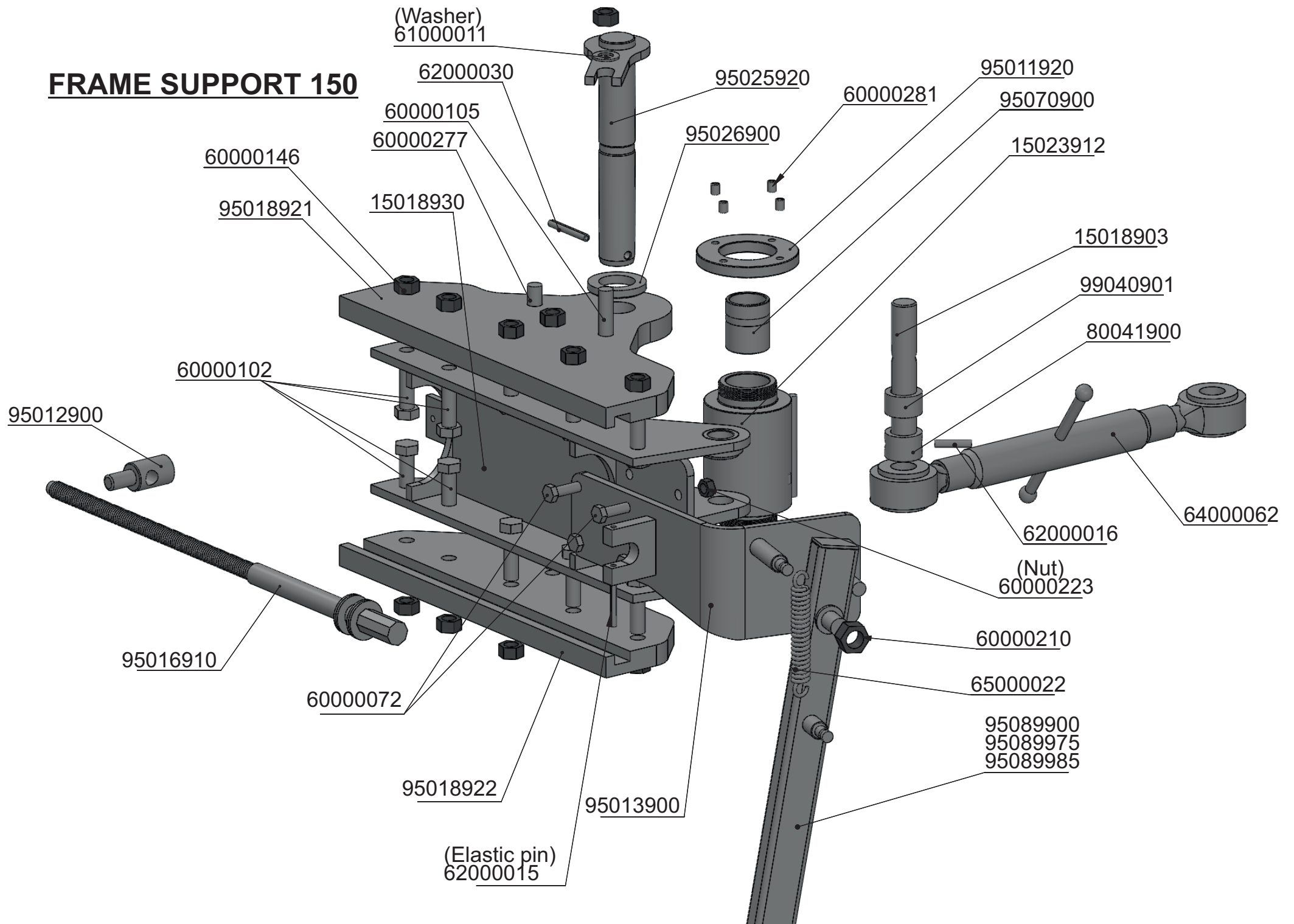

FRAME SUPPORT 150

Reference	Description	Reference	Description
15018903	TURNBUCKLE FRONT PIN D=34,6*215 mm SN	64000062	TURNBUCKLE WITH EYE D=35 30386 ZINC
15018930	FRAME SUPPORT SN-150	65000022	SPRING 225/175*26*5 195 mm
15023912	FRAME TURNING BUSH SN 150	80041900	SPACER B.P. 51/36*35 mm ZINC
53000004	GREASER MT-503 8*125 D-71412	95011920	HEADSTOCK 110/120/150 SHAFT NET LOCK
60000072	BOLT D-931 14*50 8.8	95012900	FRAME ADJUSTING NUT 120/150
60000102	BOLT D-931 20*80 8.8	95013900	STAND SUPPORT
60000105	BOLT D-931 20*90 8.8	95016910	STOP TURNBUCKLE 500 mm (D/14)
60000146	SELF LOCK NUT D-980 20 10.9 ZINC	95018921	UPPER PLATE FRAME SUPPORT 140/150
60000210	SELF LOCK NUT D-985 1" SAE 8.8	95018922	LOWER PLATE FRAME SUPPORT 140/150
60000223	SELF LOCK. NUT D-980 14 8.8 ZINC	95025920	FRAME TURN PIN S (D/03)
60000277	ALLEN BOLT D-7991 20*80 12.9	95026900	WASHER FRAME TURNING
60000281	ALLEN BOLT D-913 12*14 12.9	95070900	LAMINATED BUSH D=60/50*70 mm SS / FRAME TURNING
61000011	WASHER D-125 20	95089900	REV.STAND 70cm, 75 cm SL
62000015	ELASTIC PIN D-1481 8*80 ZINC	95089975	REV.STAND 75cm U.BEAM CLEAR.(P/02)
62000016	ELASTIC PIN D-1481 10*50 ZINC	95089985	REV.STAND 85cm
62000030	ELASTIC PIN D-1481 10*80 ZINC	99040901	SPACER B.P. 51/36*30 mm ZINC

FRAME SUPPORT 180

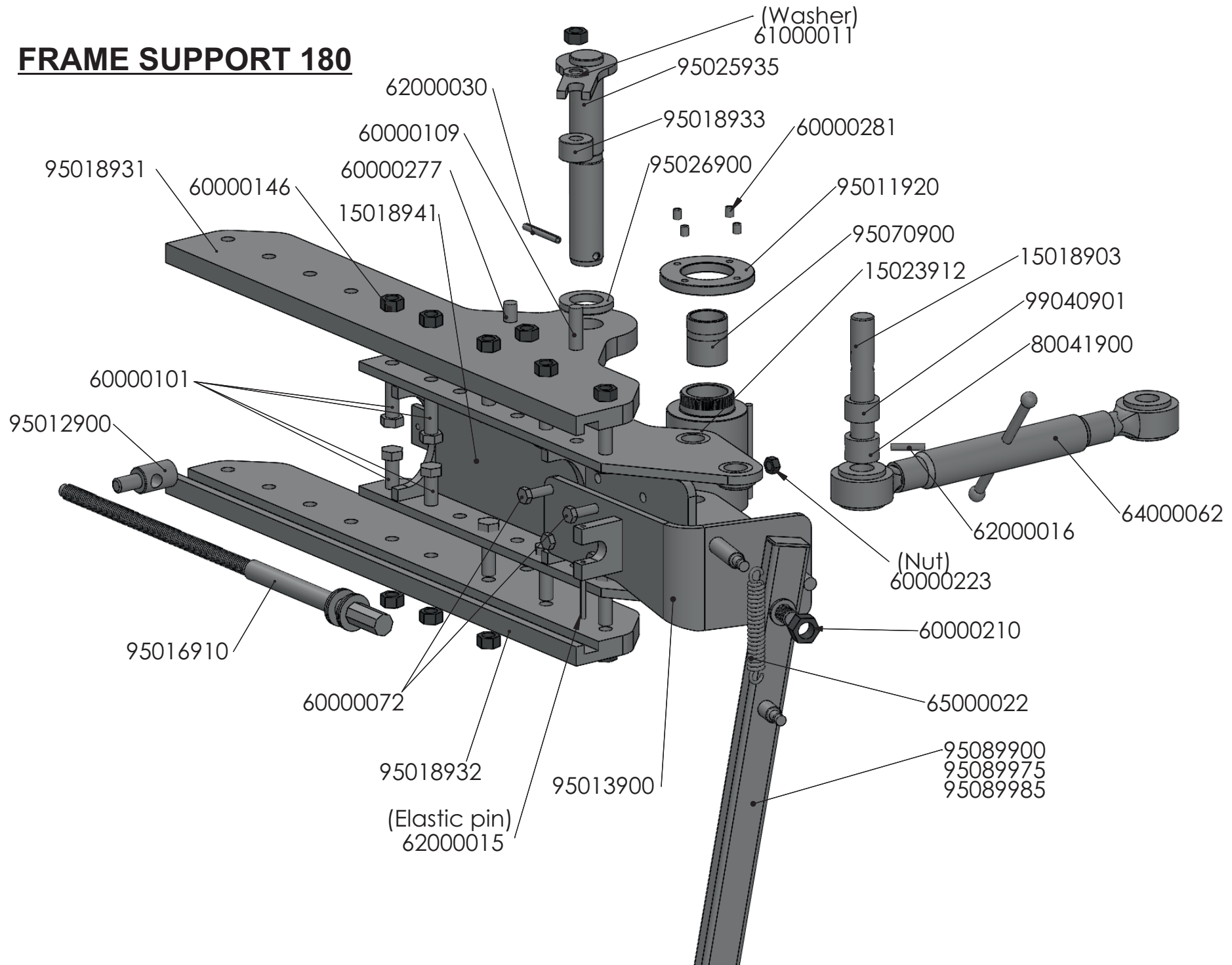

FRAME SUPPORT 180

Reference	Description	Reference	Description
15018903	TURNBUCKLE FRONT PIN D=34,6*215 mm SN	65000022	SPRING 225/175*26*5 195 mm
15018941	FRAME SUPPORT SN-6 (D/12)	80041900	SPACER B.P. 51/36*35 mm ZINC
15023912	FRAME TURNING BUSH SN 150	95011920	HEADSTOCK 110/120/150 SHAFT NET LOCK
53000004	GREASER MT-503 8*125 D-71412	95012900	FRAME ADJUSTING NUT 120/150
60000072	BOLT D-931 14*50 8.8	95013900	STAND SUPPORT
60000101	BOLT D-931 20*80 12.9 ZINC	95016910	STOP TURNBUCKLE 500 mm (D/14)
60000109	BOLT D-931 20*120 8.8	95018931	UPPER PLATE FRAME SUPPORT SN-6
60000146	SELF LOCK NUT D-980 20 10.9 ZINC	95018932	LOWER PLATE FRAME SUPPORT SN-6
60000210	SELF LOCK NUT D-985 1" SAE 8.8	95018933	SPACER D= 50/21*30mm.
60000223	SELF LOCK. NUT D-980 14 8.8 ZINC	95025935	FRAME TURN PIN D=50*402 mm SN-6
60000277	ALLEN BOLT D-7991 20*80 12.9	95026900	WASHER FRAME TURNING
60000281	ALLEN BOLT D-913 12*14 12.9	95070900	LAMINATED BUSH D=60/50*70 mm SS / FRAME TURNING
61000011	WASHER D-125 20	95089900	REV.STAND 70cm, 75 cm SL
62000015	ELASTIC PIN D-1481 8*80 ZINC	95089975	REV.STAND 75cm U.BEAM CLEAR.(P/02)
62000016	ELASTIC PIN D-1481 10*50 ZINC	95089985	REV.STAND 85cm
62000030	ELASTIC PIN D-1481 10*80 ZINC	99040901	SPACER B.P. 51/36*30 mm ZINC
64000062	TURNBUCKLE WITH EYE D=35 30386 ZINC		

ADDITIONAL BODY

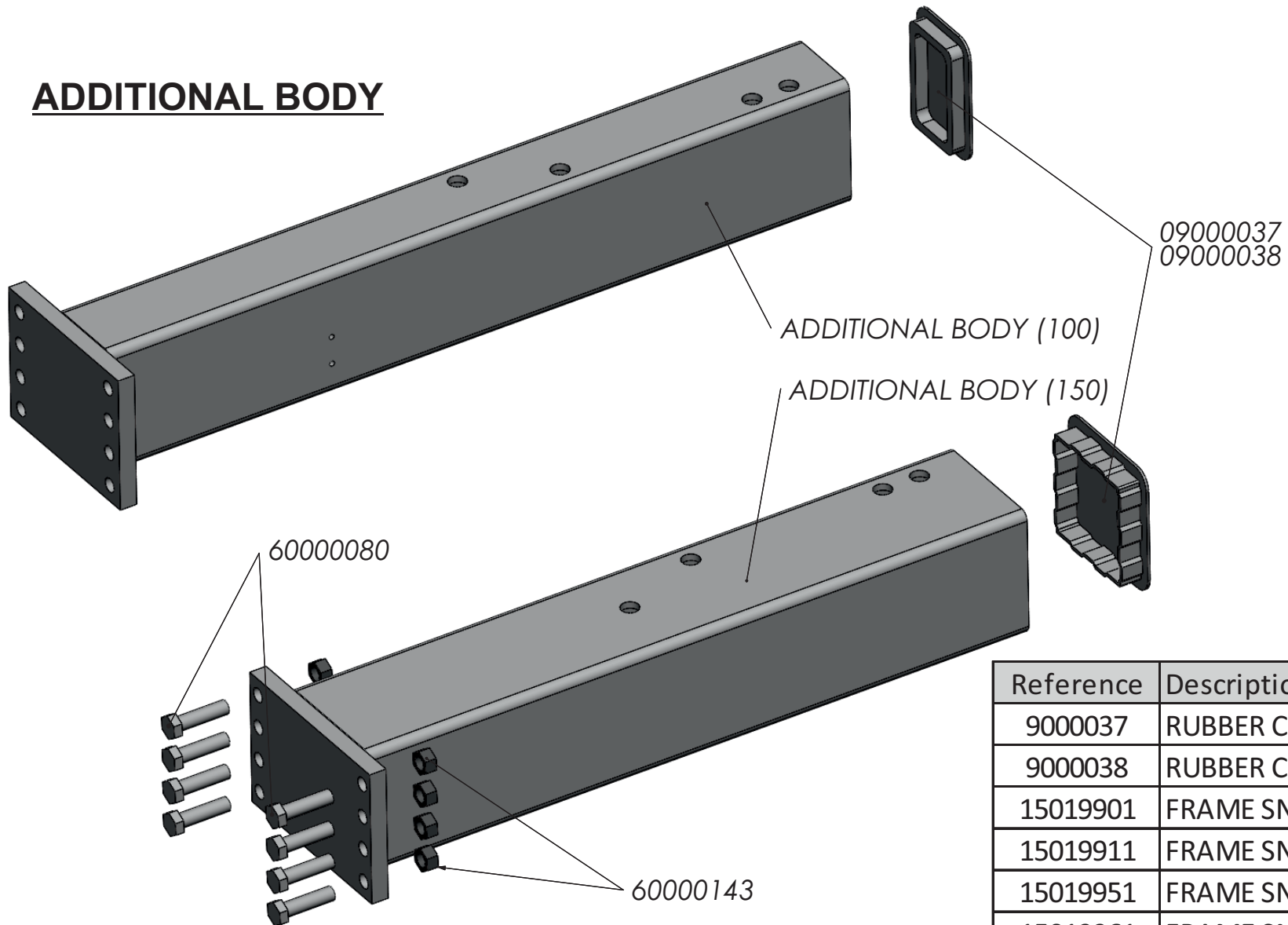

Reference	Description
9000037	RUBBER CAP 150*100*10 mm
9000038	RUBBER CAP 150*150*10 mm
15019901	FRAME SN-1-95-(100)
15019911	FRAME SN-1-85-(100)
15019951	FRAME SN-1-95-(150)
15019961	FRAME SN-1-85-(150)
16019901	FRAME SHN-1-95-(100)
16019951	FRAME SHN-1-95-(150)
60000080	BOLT D-931 16*60 8.8 ZINC
60000143	SELF LOCK NUT D-980 16 8.8 ZINC

BEAM SUPPORT SB - LB

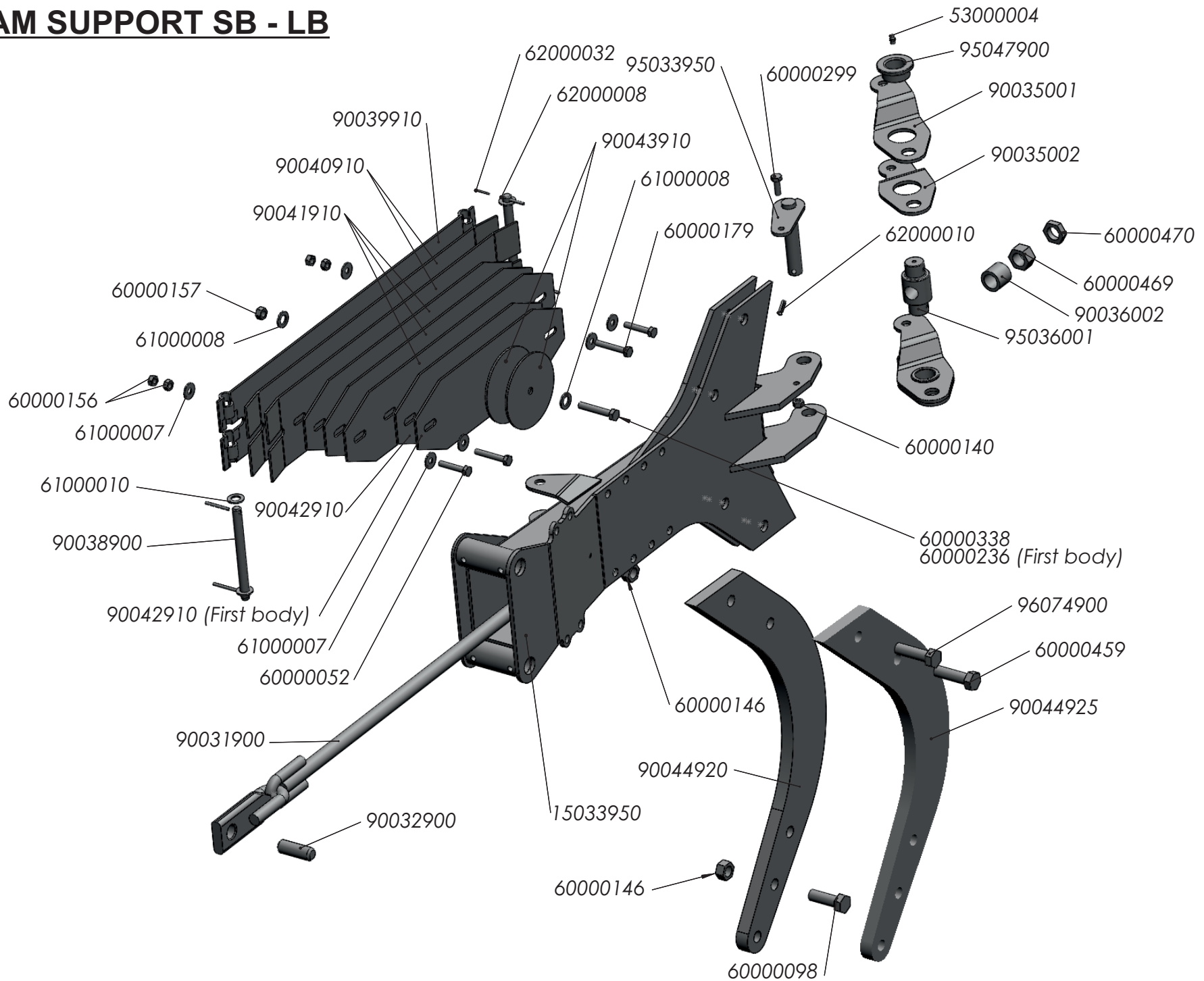

BEAM SUPPORT SB - LB

Reference	Description	Reference	Description
15033950	ARM BEAM SUPPORT SB (D/13)	62000010	ELASTIC PIN D-1481 8*40 ZINC
53000004	GREASER MT-503 8*125 D-71412	62000032	ELASTIC PIN D-1481 3*30 ZINC
60000052	BOLT D-931 10*55 10.9 ZINC	90031900	STRETCHER ROD
60000098	BOLT D-931 20*60 8.8	90032900	LEVER STRETCHER PIN D=25*70 mm
60000140	SELF LOCK. NUT D-980 10 8.8 ZINC	90035001	RIGHT ROD TURN
60000146	SELF LOCK NUT D-980 20 10.9 ZINC	90035002	LEFT ROD TURN
60000156	NUT D-934 10 8.8 ZINC	90036002	SPACER B.P. 40/28*35mm
60000157	NUT D-934 12 8.8 ZINC	90038900	LEAF SPRING PIN
60000179	BOLT D-933 10*60 10.9 ZINC	90039910	MASTER GREEN LEAF RAL-6029
60000236	BOLT D-933 12*70 8.8 ZINC	90040910	GREEN LEAF NO 1 RAL-6029
60000299	BOLT D-933 10*30 8.8	90041910	GREEN LEAF NO. 2 RAL-6029
60000338	BOLT D-931 12*65 10.9 ZINC.	90042910	GREEN LEAF NO 3 RAL-6029
60000459	BOLT 20*70 10.9	90043910	GREEN LEAF DISC RAL-6029
60000469	BOLT D-934 1" SAE 10.9 ZINC	90044920	BEAM SB 25mm 75 cm
60000470	LOW NUT D-936 1" SAE 10.9 ZINC	90044925	BEAM SB 25mm
61000007	WASHER D-9021 10 ZINC	95033950	FRAME TURN
61000008	WASHER D-125 12 ZINC	95036001	TURN
61000010	WASHER D-125 16 ZINC	95047900	TURN BUSH D=65/49,3/35*25,5 mm
62000008	ELASTIC PIN D-1481 5*30 ZINC	96074900	SHEAR BOLT 20*70 10.9

BEAM SUPPORT SH-LH

COMPONENTES PARA REPUESTO:

REF: 51000030
Juego de JUNTAS CIL. TRACCION 110/36/90

REF: 51000031
Juego de JUNTAS CIL. TRACCION 100/36/90

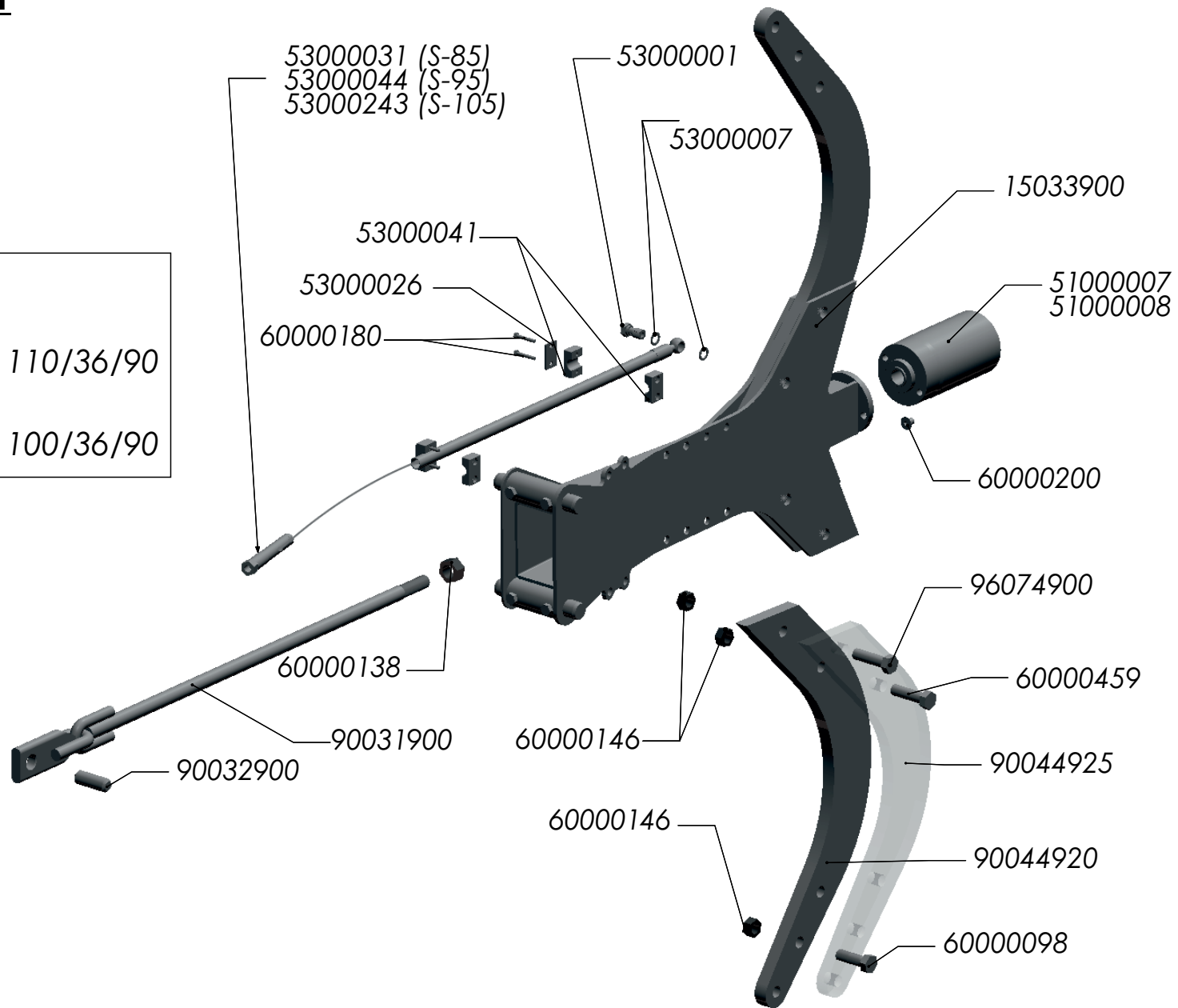

BEAM SUPPORT SH - LH

Reference	Description
15033900	ARM BEAM SUPPORT SH (D/13)
51000007	TRACTION CYLINDER 110/36/90
51000008	TRACTION CYLINDER 100/36/90
53000001	BOLT 3/8 4022
53000007	GASKET 3/8" 11602
53000026	REINFORCEMENT PLATE 20 GD3D
53000031	HYDR. TUBE 3/8" 1300 mm OR-3/8; TL-18
53000041	U-BOLT D=20mm
53000044	HYDR. TUBE 3/8*1900mm OR-3/8; TL-18
53000243	HYDR. TUBE 3/8*2000mm OR-3/8; TL-18
60000098	BOLT D-931 20*60 8.8
60000138	SELF LOCK NUT D-980 1" SAE 10.9 ZINC
60000146	SELF LOCK NUT D-980 20 10.9 ZINC
60000180	BOLT D-931 6*40 8.8 ZINC
60000200	ALLEN BOLT D-912 10*25 8.8 ZINC
60000459	BOLT 20*70 10.9
90031900	STRETCHER ROD
90032900	LEVER STRETCHER PIN D=25*70 mm
90044920	BEAM SB 25mm 75 cm
90044925	BEAM SB 25mm
96074900	SHEAR BOLT 20*70 10.9

BEAM SUPPORT LEAF XL

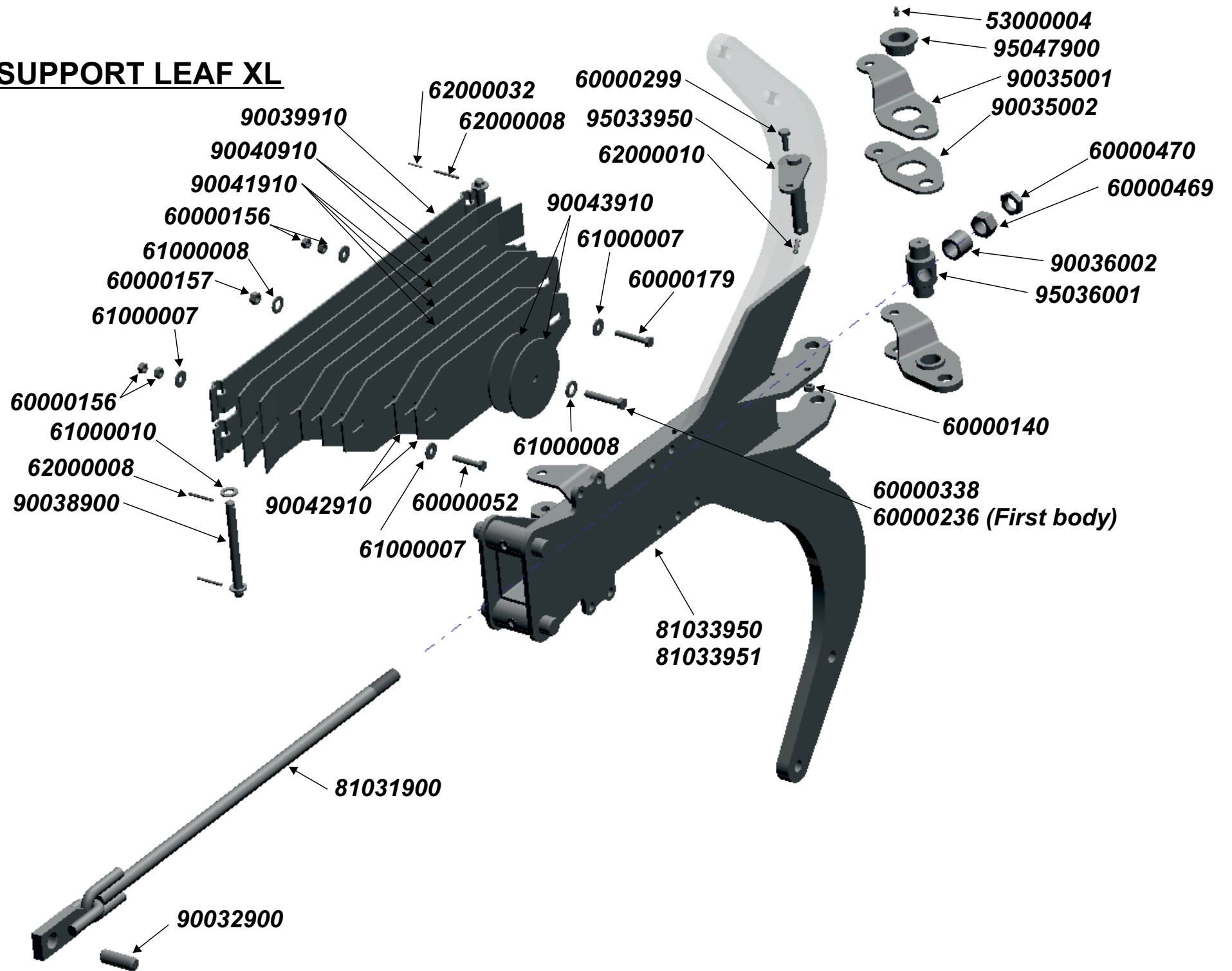

BEAM SUPPORT LEAF XL

Reference	Description	Reference	Description
53000004	GREASER MT-503 8*125 D-71412	81031900	STRETCHER ROD LVH
60000052	BOLT D-931 10*55 10.9 ZINC	81033950	BEAM SUPPORT LVB
60000140	SELF LOCK. NUT D-980 10 8.8 ZINC	81033951	BEAM SUPPORT LVB-76
60000156	NUT D-934 10 8.8 ZINC	90032900	LEVER STRETCHER PIN D=25*70 mm
60000157	NUT D-934 12 8.8 ZINC	90035001	RIGHT ROD TURN
60000179	BOLT D-933 10*60 10.9 ZINC	90035002	LEFT ROD TURN
60000236	BOLT D-933 12*70 8.8 ZINC	90036002	SPACER B.P. 40/28*35mm
60000299	BOLT D-933 10*30 8.8	90038900	LEAF SPRING PIN
60000338	BOLT D-931 12*65 10.9 ZINC.	90039910	MASTER GREEN LEAF RAL-6029
60000469	WASHER D-9021 10 ZINC	90040910	GREEN LEAF NO 1 RAL-6029
60000470	WASHER D-125 12 ZINC	90041910	GREEN LEAF NO. 2 RAL-6029
61000007	WASHER D-125 16 ZINC	90042910	GREEN LEAF NO 3 RAL-6029
61000008	ELASTIC PIN D-1481 5*30 ZINC	90043910	GREEN LEAF DISC RAL-6029
61000010	ELASTIC PIN D-1481 8*40 ZINC	95033950	FRAME TURN
62000008	ELASTIC PIN D-1481 3*30 ZINC	95036001	TURN
62000010	BOLT D-934 1" SAE 10.9 ZINC	95047900	TURN BUSH D=65/49,3/35*25,5 mm
62000032	LOW NUT D-936 1" SAE 10.9 ZINC		

BEAM SUPPORT HYDRAULIC XL

SPARE PARTS:

REF: 51000030
SEAL OIL KIT TRACTION CYLINDER 110/36/90

REF: 51000031
SEAL OIL KIT TRACTION CYLINDER 100/36/90

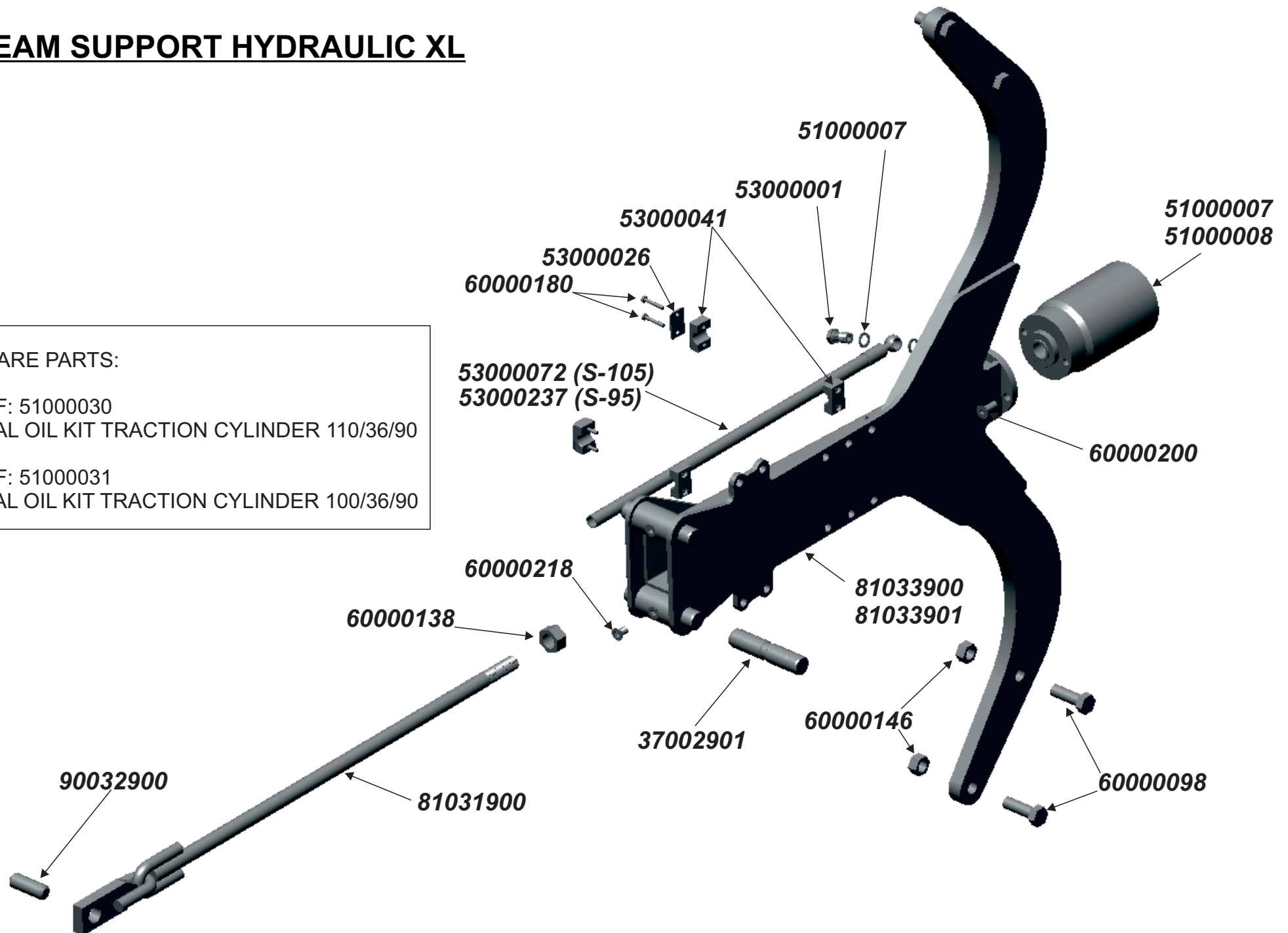

BEAM SUPPORT HYDRAULIC XL

Reference	Description
51000007	TRACTION CYLINDER 110/36/90
51000008	TRACTION CYLINDER 100/36/90
53000001	BOLT 3/8 4022
53000007	GASKET 3/8" 11602
53000026	REINFORCEMENT PLATE 20 GD3D
53000041	U-BOLT D=20mm
53000072	HYDR. TUBE 3/8*1800 mm OR-3/8; TL-18
53000237	HYDR. TUBE 3/8*1170 mm OR-3/8; TL-18
60000098	BOLT D-931 20*60 8.8
60000138	SELF LOCK NUT D-980 1" SAE 10.9 ZINC
60000146	SELF LOCK NUT D-980 20 10.9 ZINC
60000180	BOLT D-931 6*40 8.8 ZINC
60000200	ALLEN BOLT D-912 10*25 8.8 ZINC
81031900	STRETCHER ROD LVH
81033900	ARM BEAM SUPPORT LVH
81033901	ARM BEAM SUPPORT LVB-76
90032900	LEVER STRETCHER PIN D=25*70 mm

HYDROPNEUMATIC SYSTEM

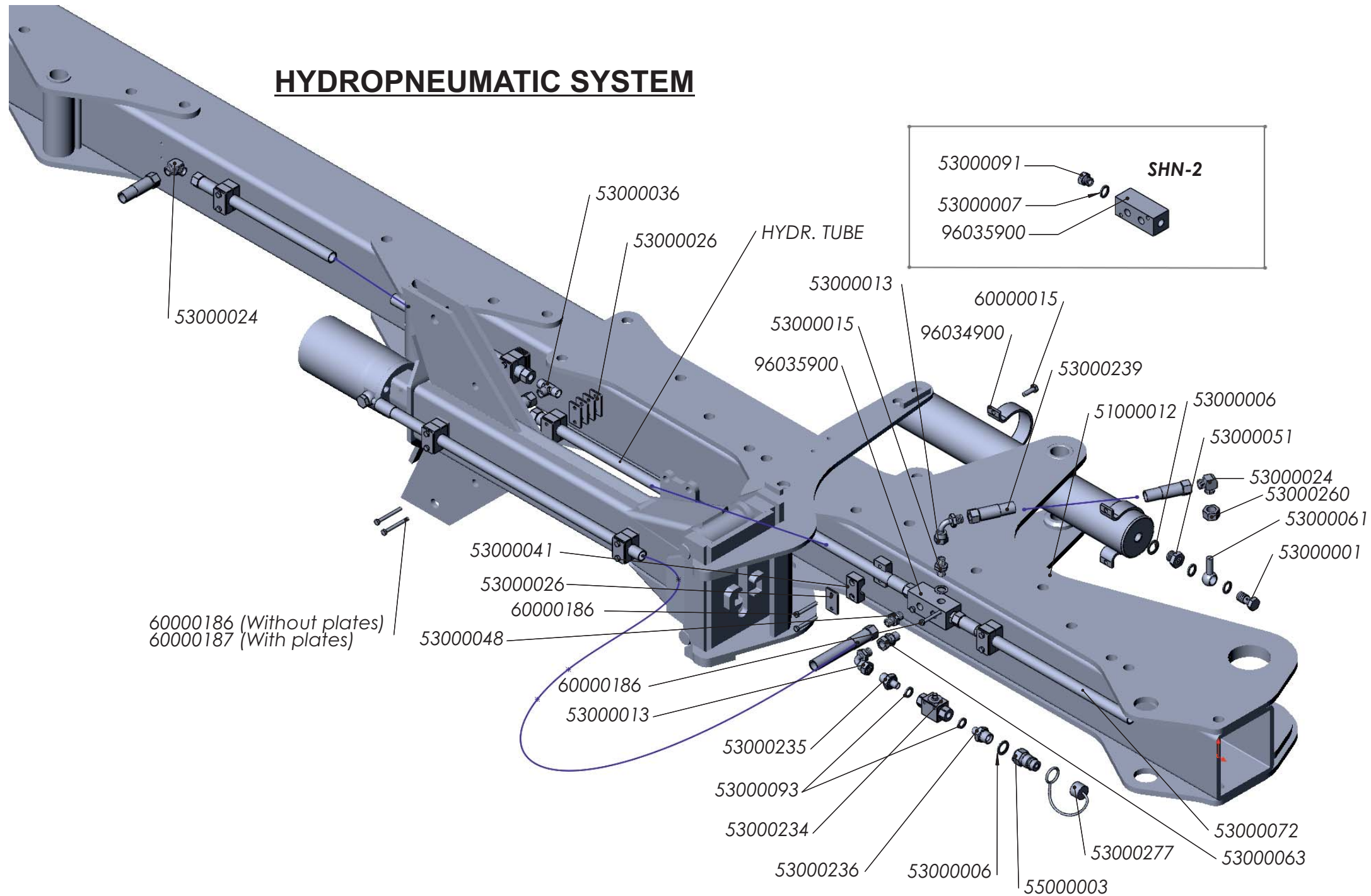

HYDROPNEUMATIC SYSTEM

Reference	Description	Reference	Description
51000012	OIL ACCUMULATOR	53000091	MALE CAP 3/8
53000001	BOLT 3/8 4022	53000093	GASKET 1/4 11601
53000006	GASKET 1/2" 11603	53000234	BALL VALVE 2/2 1/4
53000007	GASKET 3/8" 11602	53000235	REDUCTION JOINT 1/4-3/8 4071
53000013	ANGLE 90° M/F 3/8"	53000236	REDUCTION JOINT 1/4-1/2
53000015	MALE JOINT 3/8" 4062	53000239	HYDR. TUBE 3/8*420 mm TL-3/8; TL-18
53000024	TUBE/TUBE ELBOW 12mm	53000260	NUT M18*1,5 BICONE D12L
53000026	REINFORCEMENT PLATE 20 GD3D	53000277	BLUE PLUG CAP 1/2"
53000036	T CONNECTION 12	55000003	MALE FAST COUPLING 1/2" 30410108
53000041	U-BOLT D=20mm	60000015	BOLT D-933 8*25 8.8 ZINC
53000048	MALE JOINT BSP 3/8-1/2 GE12-L	60000186	BOLT D-931 6*50 8.8 ZINC
53000051	REDUCTION 1/2-3/8	60000187	BOLT D-931 6*60 8.8 ZINC
53000061	NIPPLE 3/8" 12mm LARGE	96034900	ACCUMULATOR STIRRUP
53000063	ADAPTER	96035900	PIPES SUPPORT
53000072	HYDR. TUBE 3/8*1800 mm OR-3/8; TL-18		

HYDRAULIC TUBE			
Normal		XL	
Reference	Description	Reference	Description
53000042	HYDR. TUBE 3/8*930mm TL-18; TL-18	53000042	HYDR. TUBE 3/8*930mm TL-18; TL-18
53000043	HYDR. TUBE 3/8" 830mm TL-18; TL-18	53000044	HYDR. TUBE 3/8*1900mm OR-3/8; TL-18
53000242	HYDR. TUBE 3/8*1020mm TL-18; TL-18		

HYDRAULIC TUBE OF LOAD

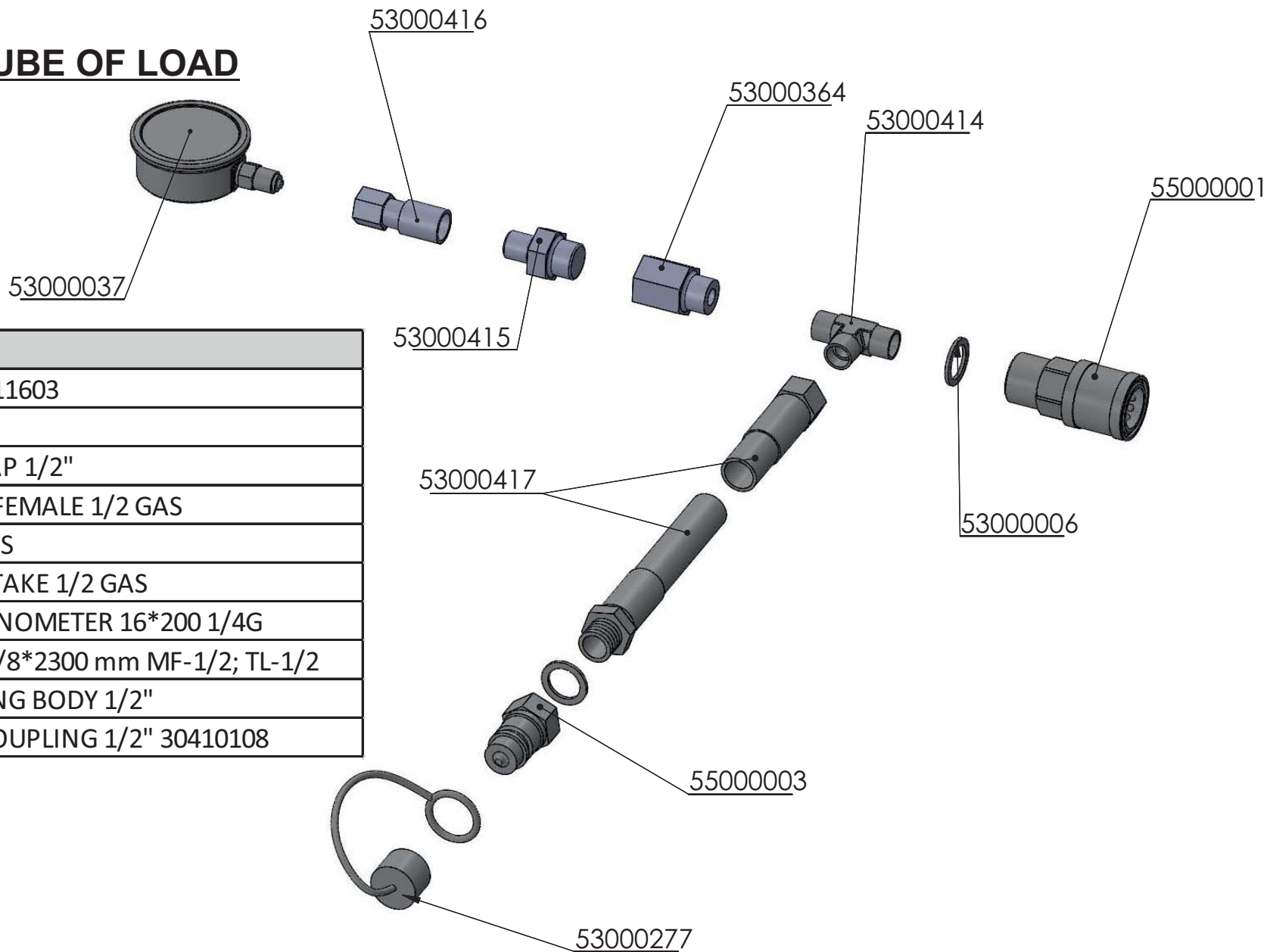

Reference	Description
53000006	GASKET 1/2" 11603
53000037	MANOMETER
53000277	BLUE PLUG CAP 1/2"
53000364	JOINT MALE/FEMALE 1/2 GAS
53000414	T M/M 1/2 GAS
53000415	PRESSURE INTAKE 1/2 GAS
53000416	ADAPTER MANOMETER 16*200 1/4G
53000417	HYDR. TUBE 3/8*2300 mm MF-1/2; TL-1/2
55000001	FAST COUPLING BODY 1/2"
55000003	MALE FAST COUPLING 1/2" 30410108

BODIES V-34 / V-74 / V-90 / V-97

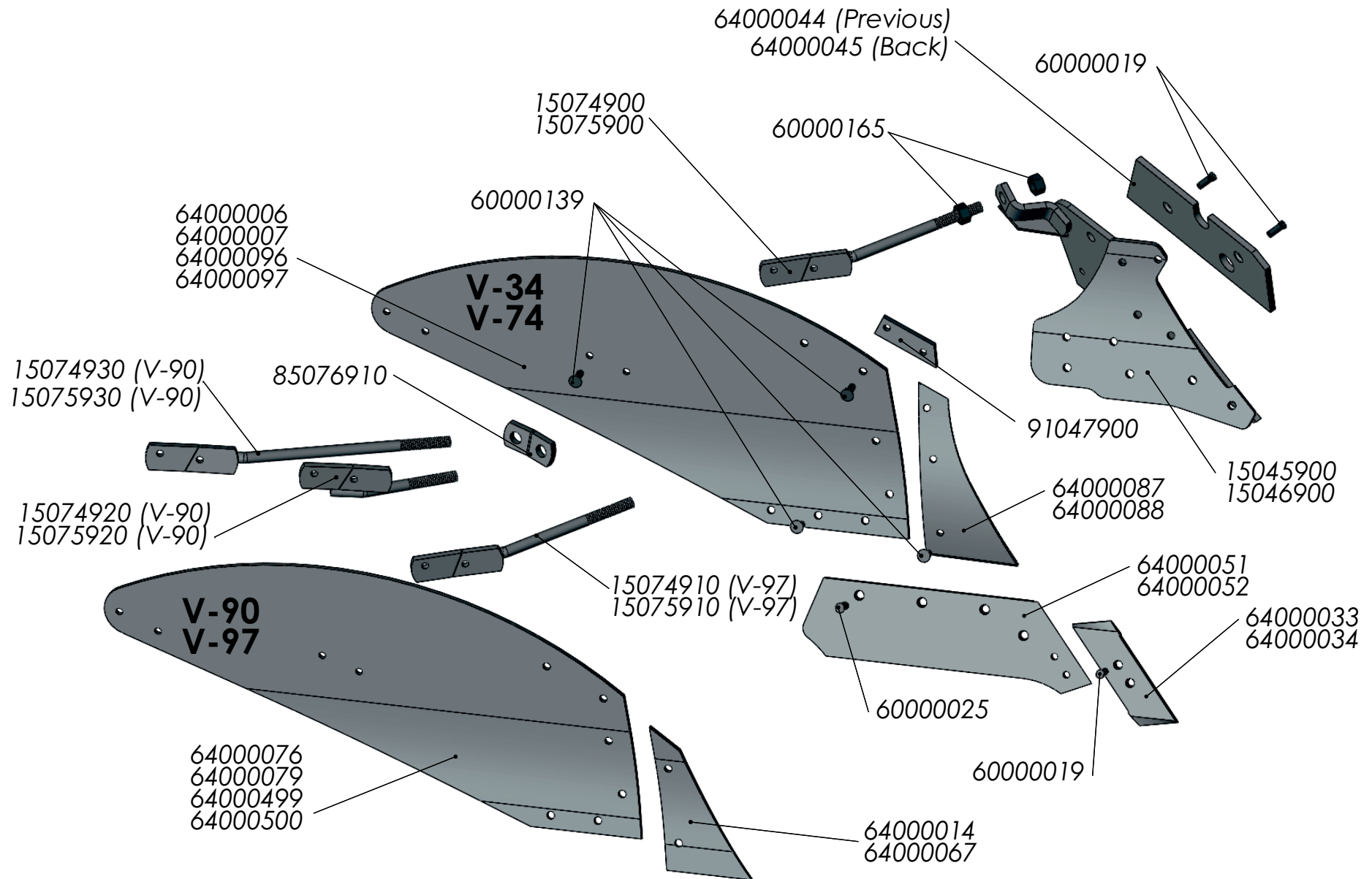

BODIES V-34 / V-74 / V-90 / V-97

Reference	Description	Reference	Description
15045900	RIGHT FROG V-97 / V-34	64000033	SHARE POINT 1365-RIGHT 65x12 mm
15046900	LEFT FROG V-97 / V-34	64000034	SHARE POINT 1365-LEFT 65x12 mm
15074900	V-34 SHORT STAY RIGHT	64000044	SHORT LANDSLIDE 2338-CAV-BAR
15074910	V-97 SHORT STAY RIGHT	64000045	LONG LANDSLIDE 2339-CAV-BAR
15074920	V-90 SHORT STAY RIGHT	64000051	SHARE V-34-17 RIGHT-CAV
15074930	V-90 LONG STAY RIGHT	64000052	SHARE V-34-17 LEFT-CAV
15075900	V-34 SHORT STAY LEFT	64000067	SHIN 1798-LEFT BORON
15075910	V-97 SHORT STAY LEFT	64000076	MOULDBOARD V-97-RIGHT LAMIN.
15075920	V-90 SHORT STAY LEFT	64000079	MOULDBOARD V-97-LEFT LAMIN.
15075930	V-90 LONG STAY LEFT	64000087	SHIN 1849-RIGHT BORON
60000019	PLOUGH BOLT 934 12*36 12.9	64000088	SHIN 1849-LEFT BORON
60000025	PLOUGH BOLT 934 14*35 12.9	64000096	MOULDBOARD V-74-RIGHT BORON
60000139	PLOUGH BOLT 934 12*35 8.8 ZINC	64000097	MOULDBOARD V-74-LEFT BORON
60000165	NUT D-934 22 8.8 ZINC	64000499	MOULDBOARD V-90-RIGHT LAMIN.
64000006	MOULDBOARD V-34-RIGHT LAMIN.	64000500	MOULDBOARD V-90-LEFT LAMIN.
64000007	MOULDBOARD V-34-LEFT LAMIN.	85076910	V-90 LONG STAY SUPPORT
64000014	SHIN 1798-RIGHT BORON CAV	91047900	CONNECT. PLATE BOARD/SHIN V-34

BODY V-40

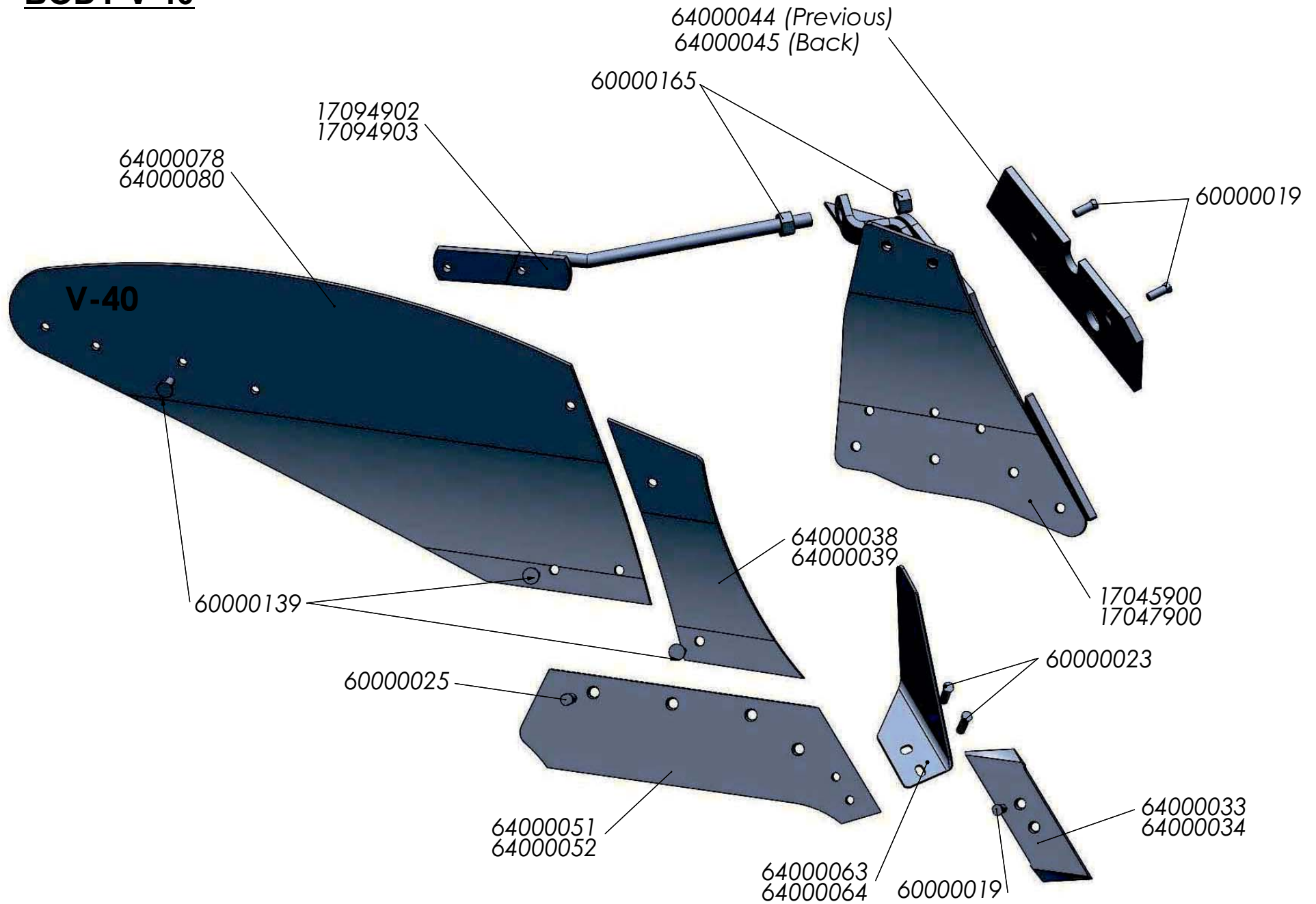

BODY V-40

Reference	Description
17045900	RIGHT FROG V-40
17047900	LEFT FROG V-40
17094902	V-40 SHORT STAY RIGHT
17094903	V-40 SHORT STAY LEFT
60000019	PLOUGH BOLT 934 12*36 12.9
60000023	PLOUGH BOLT 934 12*42 12.9
60000025	PLOUGH BOLT 934 14*35 12.9
60000139	PLOUGH BOLT 934 12*35 8.8 ZINC
60000165	NUT D-934 22 8.8 ZINC
64000033	SHARE POINT 1365-RIGHT 65x12 mm
64000034	SHARE POINT 1365-LEFT 65x12 mm
64000038	SHIN 1839-RIGHT BORON
64000039	SHIN 1839-LEFT BORON
64000044	SHORT LANDSLIDE 2338-CAV-BAR
64000045	LONG LANDSLIDE 2339-CAV-BAR
64000051	SHARE V-34-17 RIGHT-CAV
64000052	SHARE V-34-17 LEFT-CAV
64000063	SHARE KNIFE 1464-RIGHT
64000064	SHARE KNIFE 1464-LEFT
64000078	MOULDBOARD V-40-RIGHT LAMIN.
64000080	MOULDBOARD V-40-LEFT LAMIN.

BODY LOV (SLATTED)

POINTS :

en 20 mm

A: 60000465
B: 60000014

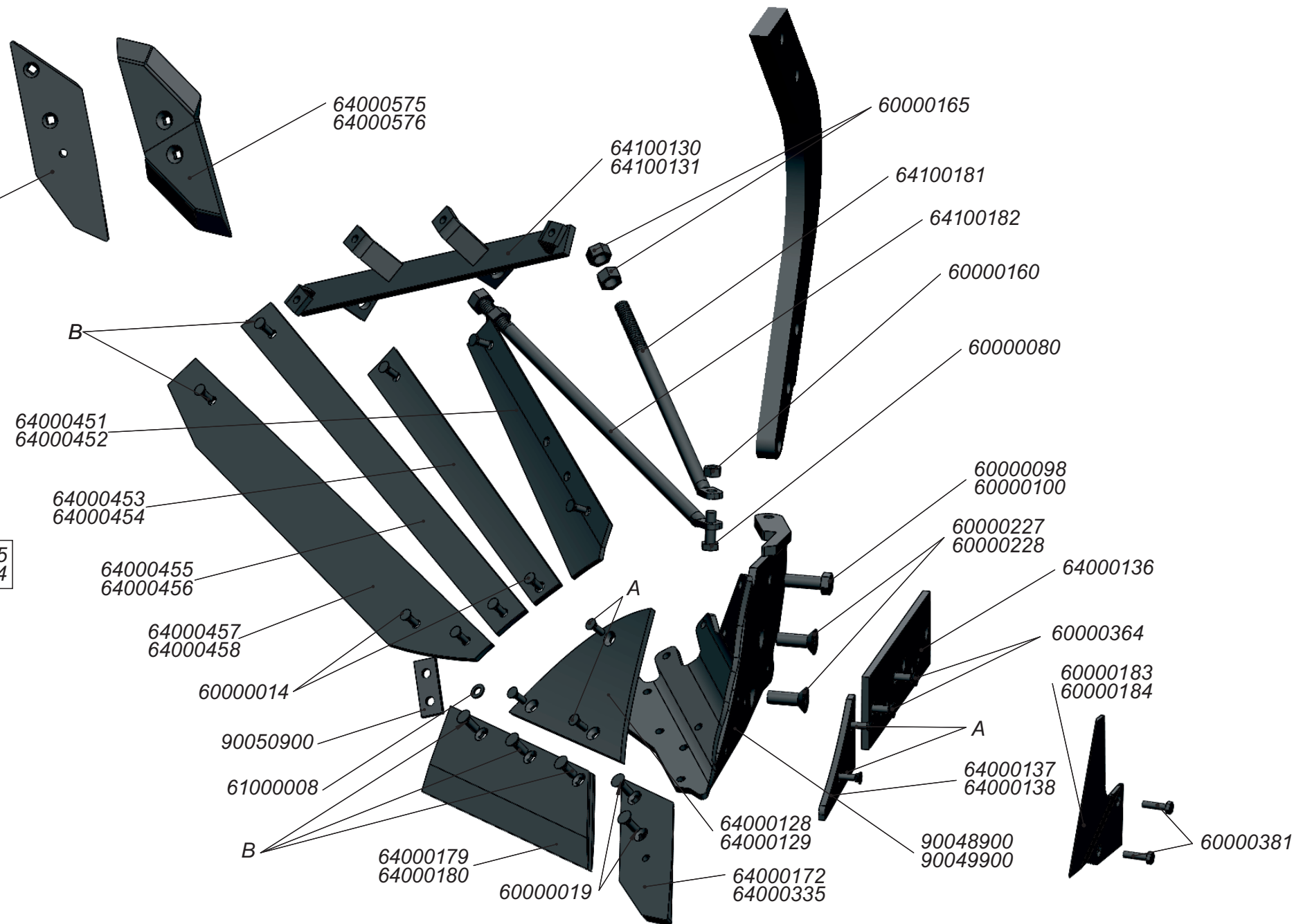

BODY LOV (SLATTED)

Reference	Description	Reference	Description
60000014	PLOUGH BOLT 12*33 12.9	64000183	SHARE KNIFE RIGHT-LK 3492890
60000019	PLOUGH BOLT 934 12*36 12.9	64000184	SHARE KNIFE LEFT-LK 3492891
60000080	BOLT D-931 16*60 8.8 ZINC	64000335	SHARE POINT LEFT 15 mm
60000098	BOLT D-931 20*60 8.8	64000451	SLAT 1-RIGHT
60000100	BOLT D-931 20*70 8.8	64000452	SLAT 1-LEFT
60000160	NUT D-934 16 8.8 ZINC	64000453	SLAT 2-RIGHT
60000165	NUT D-934 22 8.8 ZINC	64000454	SLAT 2-LEFT
60000227	ALLEN BOLT D-7991 20*60 10.9	64000455	SLAT 3-RIGHT
60000228	ALLEN BOLT D-7991 20*70 10.9	64000456	SLAT 3-LEFT
60000381	PLOUGH BOLT D-608/934 10*40 8.8	64000457	SLAT 4-RIGHT
60000465	PLOUGH BOLT 934 10*33 12.9	64000458	SLAT 4-LEFT
61000008	WASHER D-125 12 ZINC	64000575	SHARE POINT RIGHT REVERS.
64000128	SHIN RIGHT	64000576	SHARE POINT LEFT REVERS.
64000129	SHIN LEFT	64100130	SUPPORT WITH STAYS RIGHT SLATTED
64000136	LANDSLIDE RIGHT/LEFT	64100131	SUPPORT WITH STAYS LEFT SLATTED
64000137	LANDSLIDE POINT RIGHT	64100181	SHORT STAY SLATT.MOULDB.
64000138	LANDSLIDE POINT LEFT	64100182	LONG STAY SLATT.MOULDB.
64000172	SHARE POINT RIGHT 15 mm	90048900	PLOUGH BODY SLATTED RIGHT
64000179	SHARE 20" RIGHT	90049900	PLOUGH BODY SLATTED LEFT
64000180	SHARE 20" LEFT	90050900	CONNECT.PLATE BOARD/SHARE SLATTED

SKIMMERS SB

LARGE CAPACITY

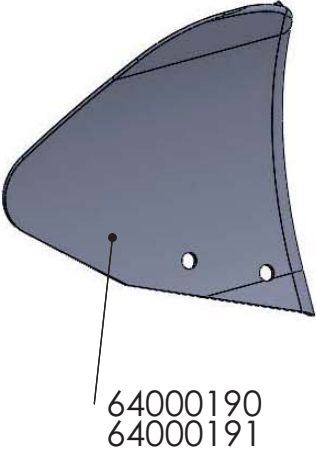

GRASS

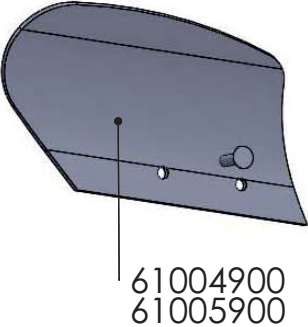

MAIZE

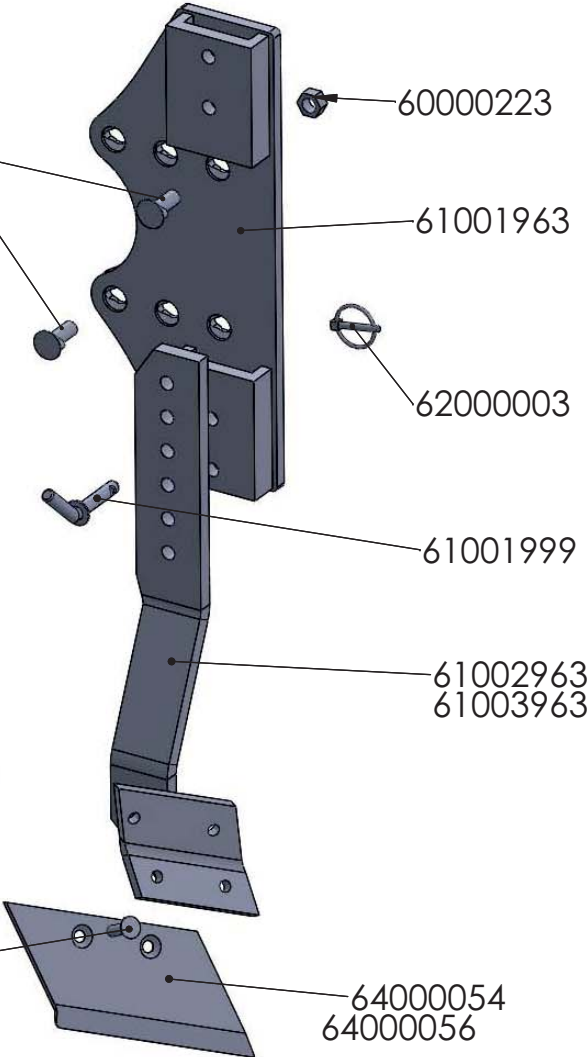
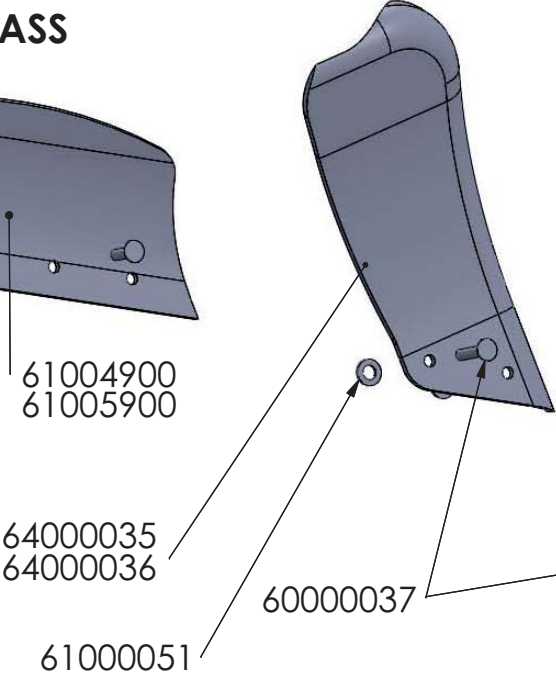

SKIMMERS SB

Reference	Description
60000037	PLOUGH BOLT 934 10*35 10.9 ZINC
60000213	PLOUGH BOLT 10*45 10.9 ZINC
60000223	SELF LOCK. NUT D-980 14 8.8 ZINC
60000432	PLOUGH BOLT D-934 14*40 10.9 ZINC
61000051	WASHER D-125 10 ZINC
61001963	SUPPORT SKIMMER SBHN D/76 cm (D/13)
61001999	REGULATION SKIMMER PIN D=12*120 mm
61002963	SKIMMER ARM SB/H-LVB/H RIGTH (D/13-AG)
61003963	SKIMMER ARM SB/H-LVB/H LEFT (D/13-AG)
61004900	RIGHT GRASS SKIM. 1855 BORON
61005900	LEFT GRASS SKIM. 1855 BORON
62000003	RING SPLIT PIN 6 ZINC
64000035	RIGHT MAIZE SKIM. 1820 BORON
64000036	LEFT MAIZE SKIM. 1820 BORON
64000054	SKIM. SHARE 1394 RIGHT
64000056	SKIM. SHARE 1394 LEFT
64000190	RIGHT SKIM 1705 BORON
64000191	LEFT SKIM 1705 BORON

SKIMMERS XL

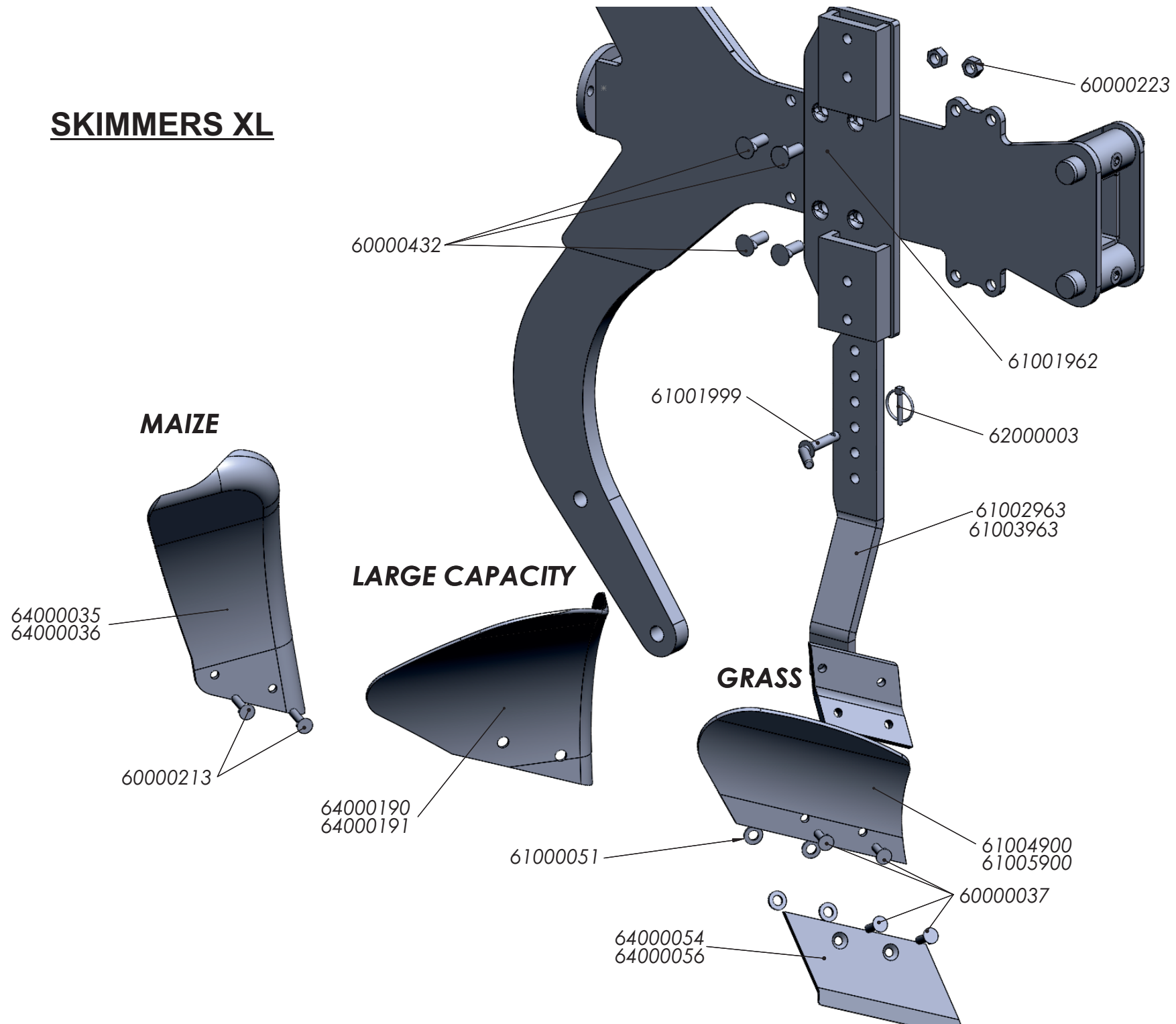

SKIMMERS XL

Reference	Description
60000037	PLOUGH BOLT 934 10*35 10.9 ZINC
60000213	PLOUGH BOLT 10*45 10.9 ZINC
60000223	SELF LOCK. NUT D-980 14 8.8 ZINC
60000432	PLOUGH BOLT D-934 14*40 10.9 ZINC
61000051	WASHER D-125 10 ZINC
61001962	SUPPORT SKIMMER LVH D/76 (D/13)
61001999	REGULATION SKIMMER PIN D=12*120 mm
61002963	SKIMMER ARM SB/H-LVB/H RIGTH (D/13-AG)
61003963	SKIMMER ARM SB/H-LVB/H LEFT (D/13-AG)
61004900	RIGHT GRASS SKIM. 1855 BORON
61005900	LEFT GRASS SKIM. 1855 BORON
62000003	RING SPLIT PIN 6 ZINC
64000035	RIGHT MAIZE SKIM. 1820 BORON
64000036	LEFT MAIZE SKIM. 1820 BORON
64000054	SKIM. SHARE 1394 RIGHT
64000056	SKIM. SHARE 1394 LEFT
64000190	RIGHT SKIM 1705 BORON
64000191	LEFT SKIM 1705 BORON

TRASH BOARDS

V-40

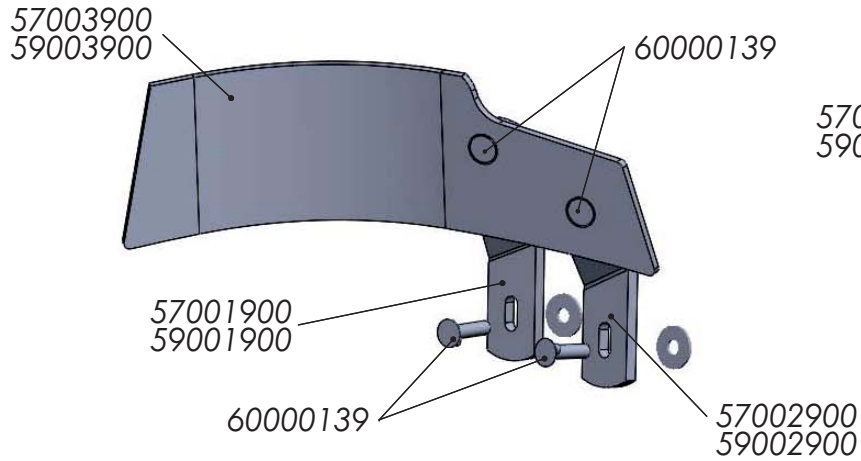

V-34 / V-74

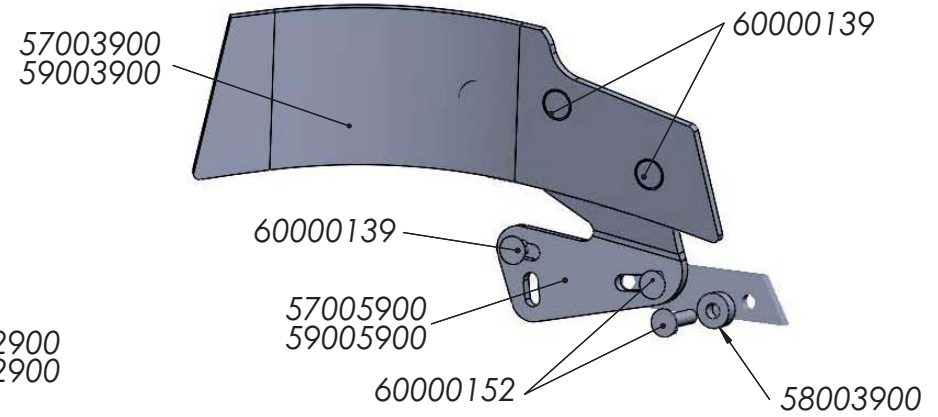

V-LOV

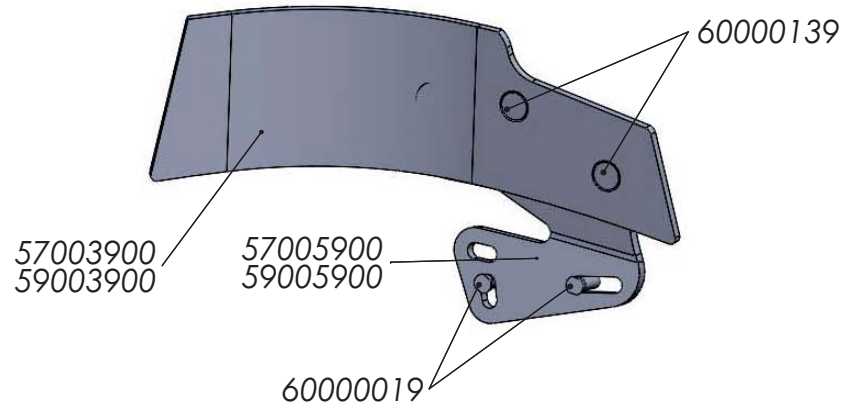

V-90 / V-97

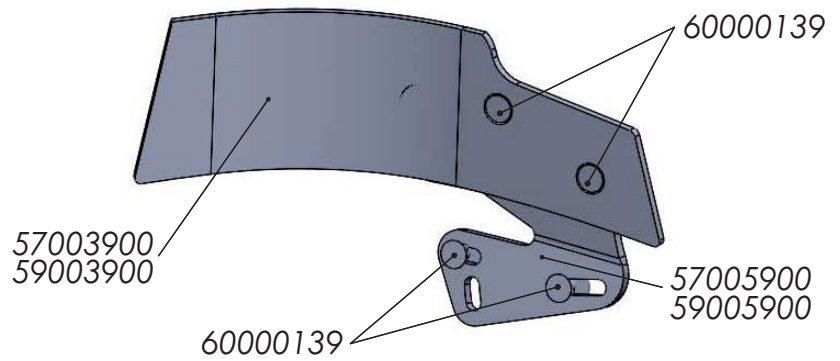

TRASH BOARDS

Reference	Description
57001900	REAR SUPP. TRASH B. V-40 RIGHT
57002900	FRONT SUPPORT TRASH B. V-40 RIGHT
57003900	TRASH BOARD 1856-RIGHT BORON
57005900	SUPP. RIGHT TRASH B. V-97 / V-34 / V-LOV)
58003900	BUSH D=30/13*12 mm SPACER SUPPORT V-34 ZINC
59001900	REAR SUPPORT TRASH B. V-40 LEFT
59002900	FRONT SUPPORT TRASH B. V-40 LEFT / REAR TRASH 1701
59003900	TRASH BOARD 1856-LEFT BORON
59005900	SUPP. LEFT TRASH B. V-97 / V-34 / V-LOV
60000019	PLOUGH BOLT 934 12*36 12.9
60000139	PLOUGH BOLT 934 12*35 8.8 ZINC
60000152	PLOUGH BOLT 934 12*45 8.8 ZINC

DISC COULTERS

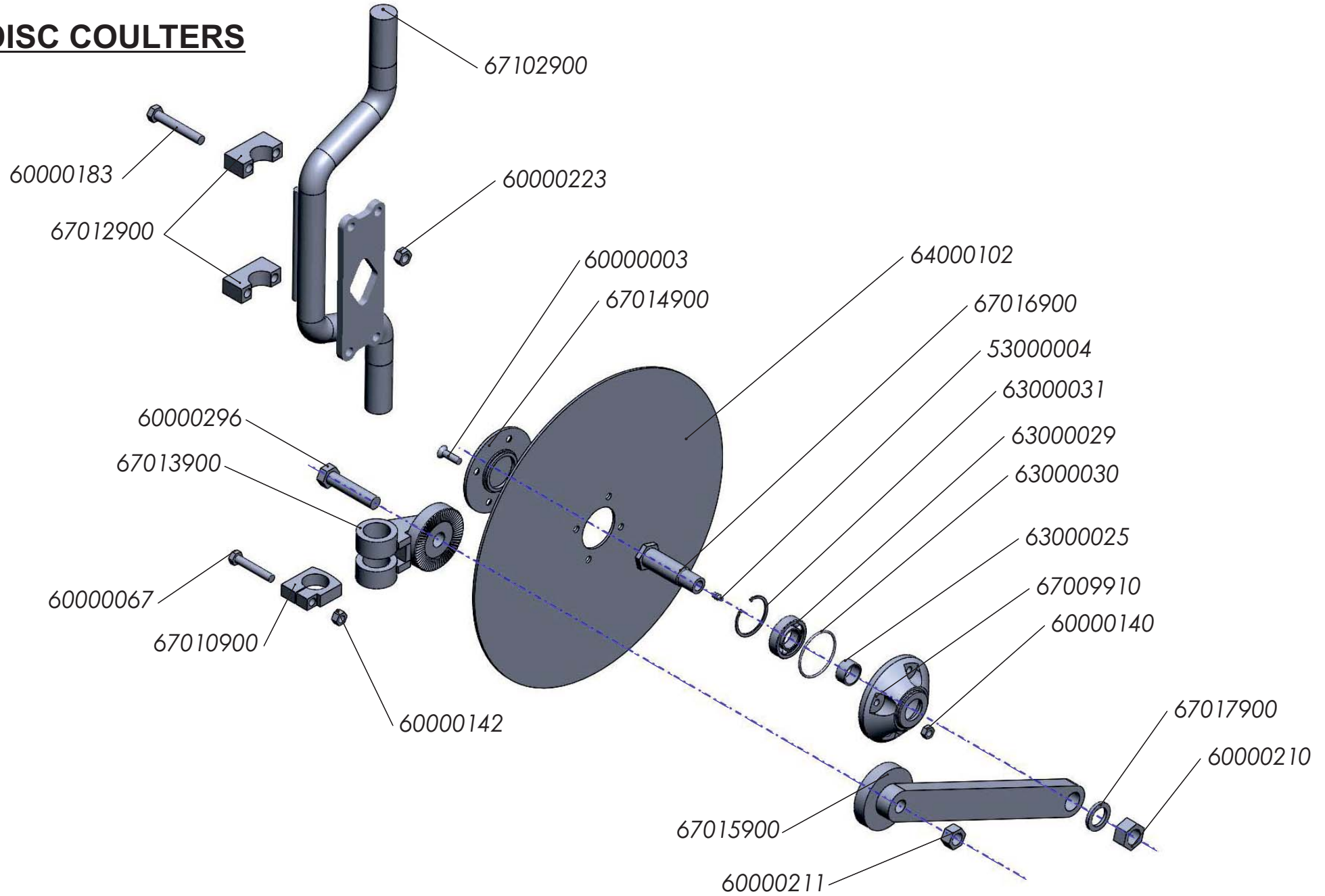

DISC COULTERS

Reference	Description	Reference	Description
53000004	GREASER MT-503 8*125 D-71412	63000030	OIL SEAL 35-52-7
60000003	ALLEN BOLT D-7991 10*40 10.9 ZINC	63000031	ELASTIC RING D-472 62
60000067	BOLT D-931 12*70 8.8 ZINC	64000102	DISC COULTER ED 5 1983-20" R-68
60000140	SELF LOCK. NUT D-980 10 8.8 ZINC	67009910	20" DISC HUB
60000142	SELF LOCK NUT D-980 12 8.8 ZINC	67010900	ADJUSTMENT PLATE
60000183	BOLT D-931 14*90 8.8 ZINC	67012900	LOCK U-BOLT ZINC
60000210	SELF LOCK NUT D-985 1" SAE 8.8	67013900	TURN SUPPORT 20" DISC
60000211	SELF LOCK NUT D-985 20 8.8	67014900	DISC CAP
60000223	SELF LOCK. NUT D-980 14 8.8 ZINC	67015900	20" DISC ARM
60000296	BOLT D-931 20*90 8.8 ZINC	67016900	SHAFT 20" DISCS
63000025	INSIDE RING 30*35*17	67017900	WASHER 20" DISC SHAFT
63000029	BEARING 3206	67102900	DISC COULTERS ARM SB/SH

NON STOP DISC COULTERS

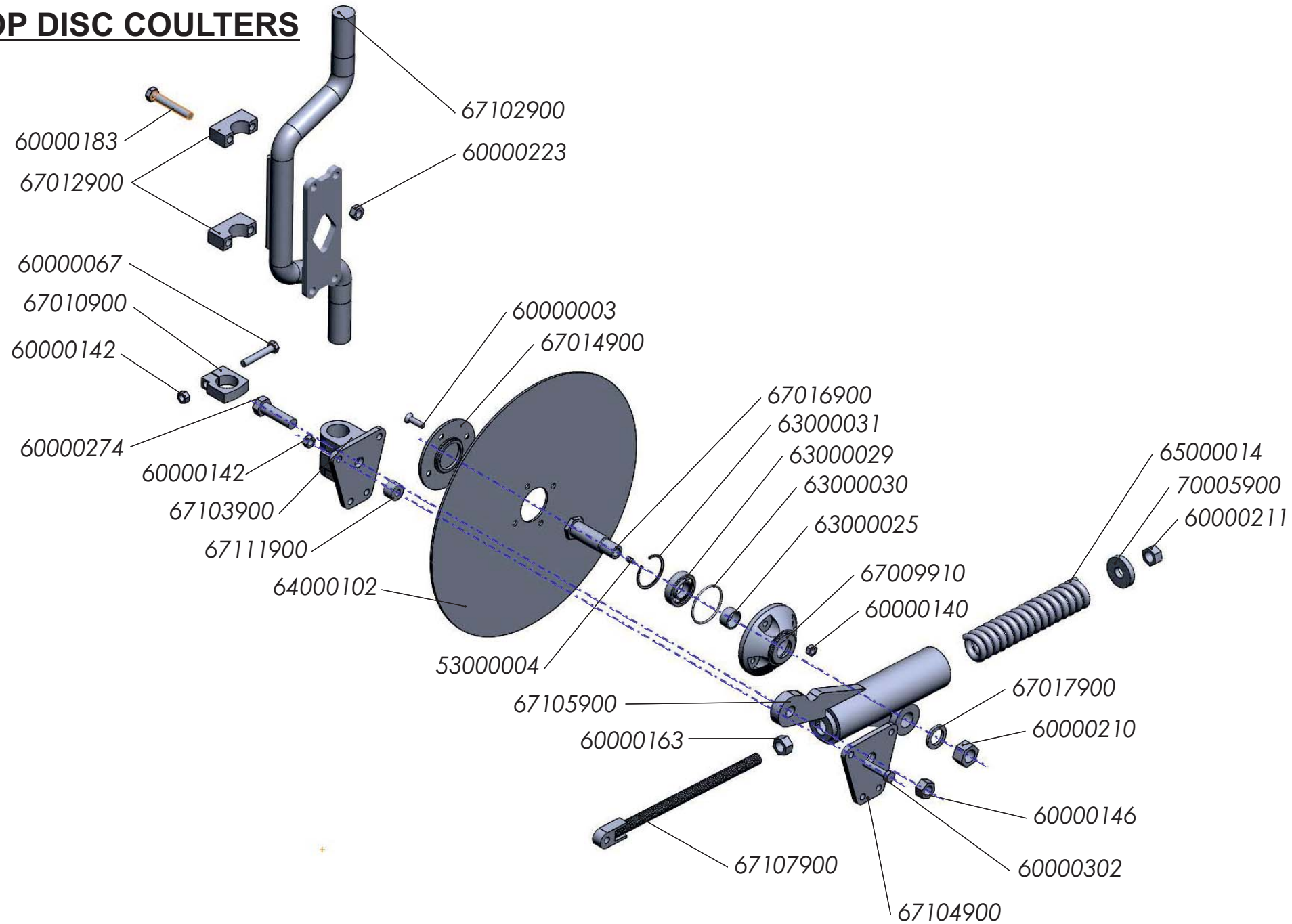

NON STOP DISC COULTERS

Reference	Description	Reference	Description
53000004	GREASER MT-503 8*125 D-71412	63000031	ELASTIC RING D-472 62
60000003	ALLEN BOLT D-7991 10*40 10.9 ZINC	64000102	DISC COULTER ED 5 1983-20" R-68
60000067	BOLT D-931 12*70 8.8 ZINC	65000014	COMPRESSION CYLINDER SPRING 110*40*5 ZINC
60000140	SELF LOCK. NUT D-980 10 8.8 ZINC	67009910	20" DISC HUB
60000142	SELF LOCK NUT D-980 12 8.8 ZINC	67010900	ADJUSTMENT PLATE
60000146	SELF LOCK NUT D-980 20 10.9 ZINC	67012900	LOCK U-BOLT ZINC
60000163	NUT D-934 20 8.8 ZINC	67014900	DISC CAP
60000183	BOLT D-931 14*90 8.8 ZINC	67016900	SHAFT 20" DISCS
60000210	SELF LOCK NUT D-985 1" SAE 8.8	67017900	WASHER 20" DISC SHAFT
60000211	SELF LOCK NUT D-985 20 8.8	67102900	DISC COULTERS ARM SB/SH
60000223	SELF LOCK. NUT D-980 14 8.8 ZINC	67103900	SPRING-LOADED DISC TURN
60000274	BOLT D-931 20*70 8.8 ZINC	67104900	PLATE TURN SUPPORT SP.LOADED DISC
60000302	BOLT D-931 12*55 8.8	67105900	SPRING-LOAD. DISC ARM
63000025	INSIDE RING 30*35*17	67107900	SPRING-LOADED DISC ROD
63000029	BEARING 3206	67111900	SPACER SP.-LOADED DISC TURN
63000030	OIL SEAL 35-52-7	70005900	REINF. WASHER 58*21 E-10mm

CONTROL WHEEL

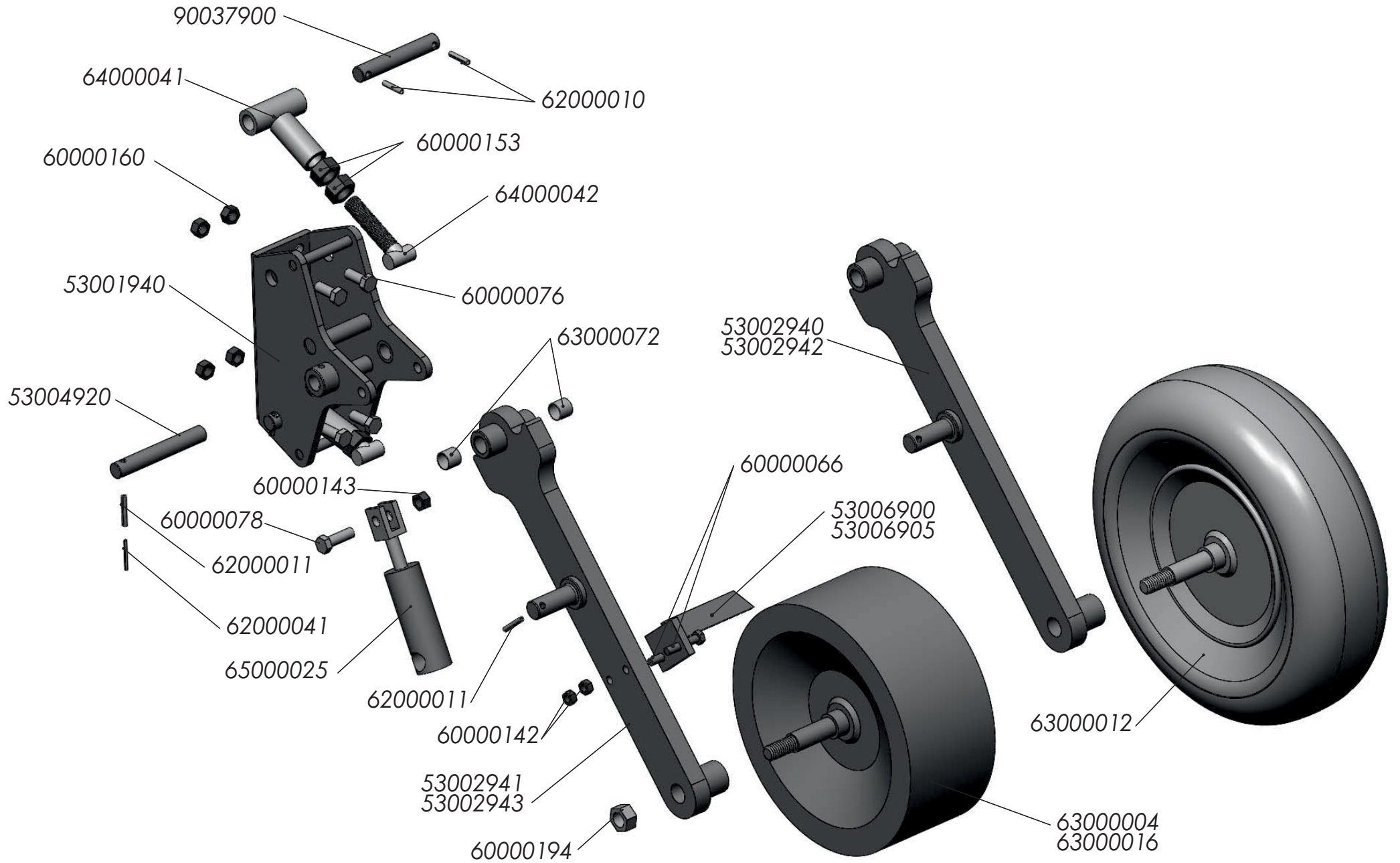

CONTROL WHEEL 608 - 685

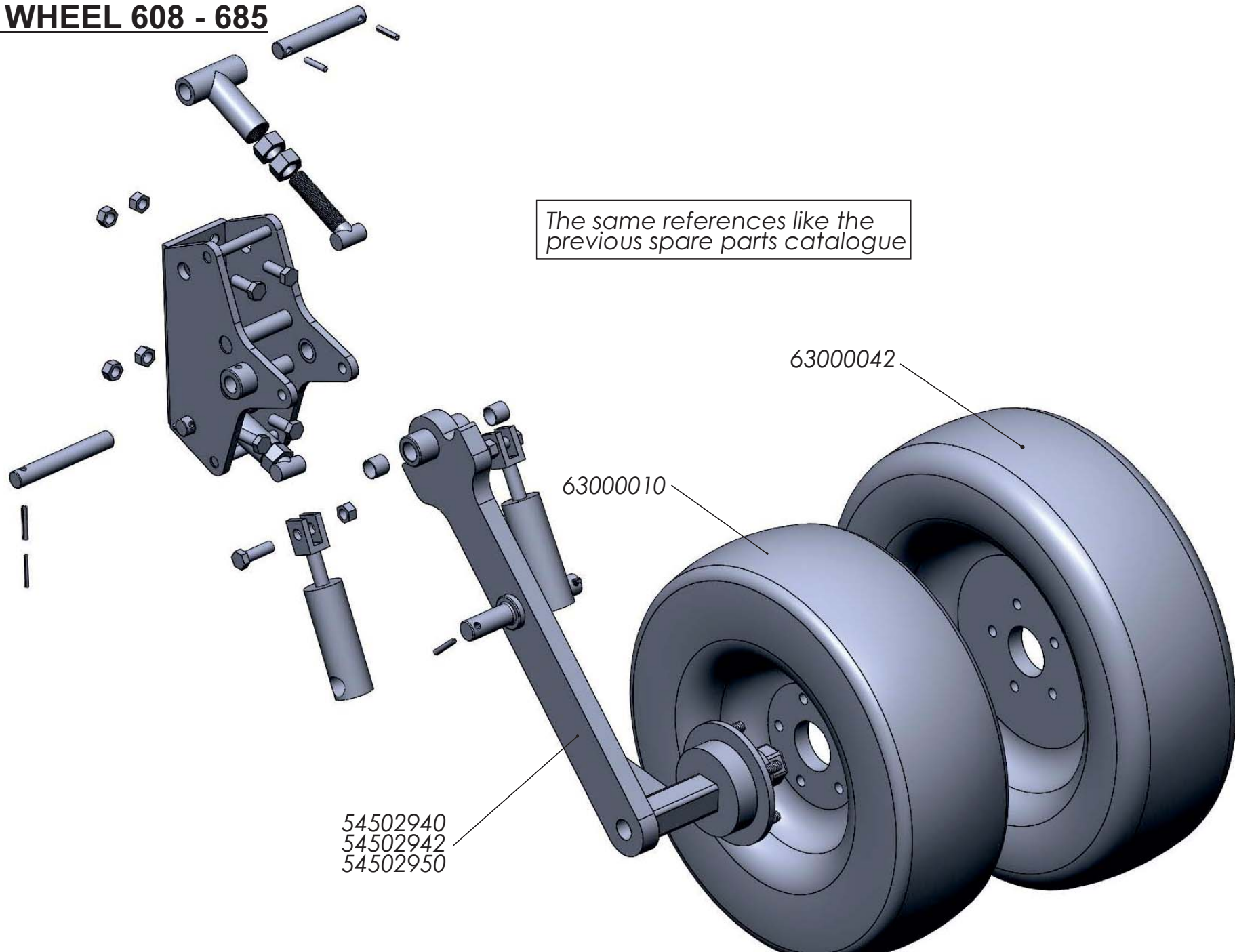

The same references like the previous spare parts catalogue

CONTROL WHEEL

Reference	Description	Reference	Description
53001940	WHEEL BRACKET	60000153	NUT D-934 1" SAE 8.8 ZINC
53002940	RUBBER WHEEL ARM REV.PLOUGH (D/04)	60000160	NUT D-934 16 8.8 ZINC
53002941	METALLIC WHEEL ARM REV.PLOUGH (D/04)	60000194	SELF LOCK. NUT D-980 24/200 8.8
53002942	RUBBER WHEEL ARM REV. PLOUGH 85 (D/04)	62000010	ELASTIC PIN D-1481 8*40 ZINC
53002943	METALLIC WHEEL ARM REV. PLOUGH 85 (D/04)	62000011	ELASTIC PIN D-1481 8*50 ZINC
53004920	PIN D=25*175 mm WHEEL ARM	62000041	ELASTIC PIN DIN-1481 5*50
53006900	WHEEL SCRAPER	63000004	METAL WHEEL 400*170*3 RAL-3001
53006905	WHEEL SCRAPER (5)	63000010	RUBBER WHEEL 200/60*14,5"-10PR RAL-6029
54502940	WHEEL ARM (608*205). REV (D/04)	63000012	RUBBER WHEEL 6.00*9"-10 PR V50 RAL-6029
54502942	WHEEL ARM (608*205/685*260) D/85 cm	63000016	METAL WHEEL 500*180*3 RAL-3001
54502950	WHEEL ARM (685*260). REV (D/04)	63000042	RUBBER WHEEL 250/65*14,5"- 12PR RAL-6029
60000066	BOLT D-931 12*60 8.8 ZINC	63000072	BUSH PAP 2525 P10
60000076	BOLT D-933 16*40 8.8 ZINC	64000041	DEPTH STOP SUPPORT ZINC
60000078	BOLT D-933 16*50 8.8 ZINC	64000042	DEPTH STOP TREATY + ZINC
60000142	SELF LOCK NUT D-980 12 8.8 ZINC	65000025	DEADENER W/FORK 20/50/39
60000143	SELF LOCK NUT D-980 16 8.8 ZINC	90037900	PIN D=25*154 mm WHEEL STOPPER

CONT. / TRANS. WHEEL

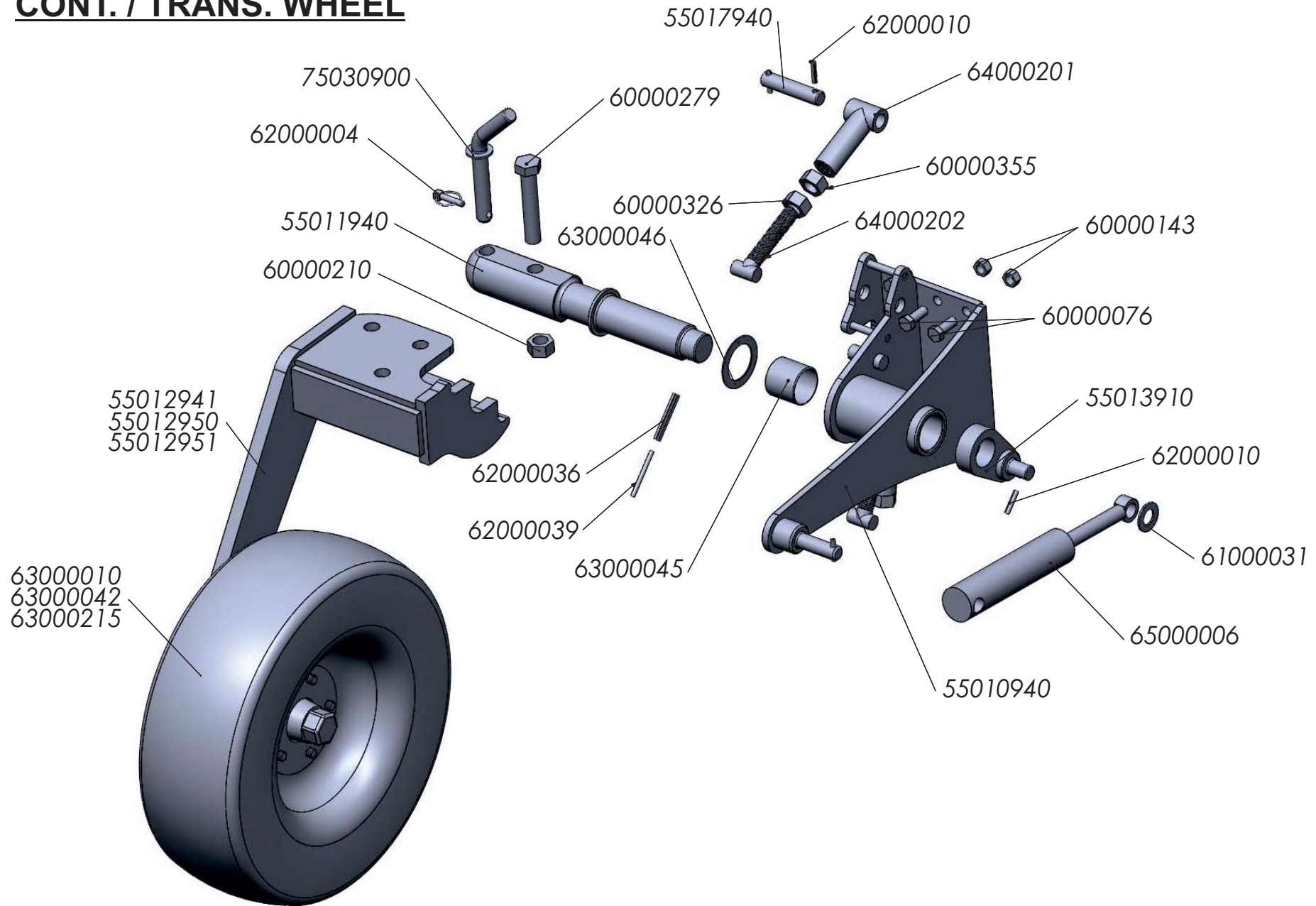

CONT. / TRANS. WHEEL

Reference	Description	Reference	Description
55010940	WHEEL BRACKET C/T (D/03)	62000004	RING SPLIT PIN 10 ZINC
55011940	SHAFT TRANSPORT WHEEL (D/03)	62000010	ELASTIC PIN D-1481 8*40 ZINC
55012941	C/T WHEEL ARM (608*205/685*260) D/85 (D/03)	62000036	ELASTIC PIN D-1481 12*80 ZINC
55012950	C/T WHEEL ARM (608*205/685*260) (D/03)	62000039	ELASTIC PIN D-1481 7*80 ZINC
55012951	C/T WHEEL ARM (686*304) (D/03)	63000010	RUBBER WHEEL 200/60*14,5"-10PR RAL-6029
55013910	C/T WHEEL LOCK (D/02)	63000042	RUBBER WHEEL 250/65*14,5"- 12PR RAL-6029
55017940	TRANSPORT WHEEL STOP PIN D=25*116 mm	63000045	BUSH PAP 6060 P10
60000076	BOLT D-933 16*40 8.8 ZINC	63000046	DISC PAW 62 P10
60000143	SELF LOCK NUT D-980 16 8.8 ZINC	63000215	RUBBER WHEEL 320/60-12 132A8 421TT
60000210	SELF LOCK NUT D-985 1" SAE 8.8	64000201	DEPTH STOP SUPPORT
60000279	BOLT 1"*135 SAE 12.9 ZINC	64000202	WHEEL DEPTH STOP
60000326	LOW NUT D-936 30/200 8.8 ZINC	65000006	DEADENER 25/50/145
60000355	STOP NUT TURNOVER 30/200 8.8 ZINC	75030900	TURNING PIN D=25*255 mm
61000031	WASHER 26 ZINC		

LOCK

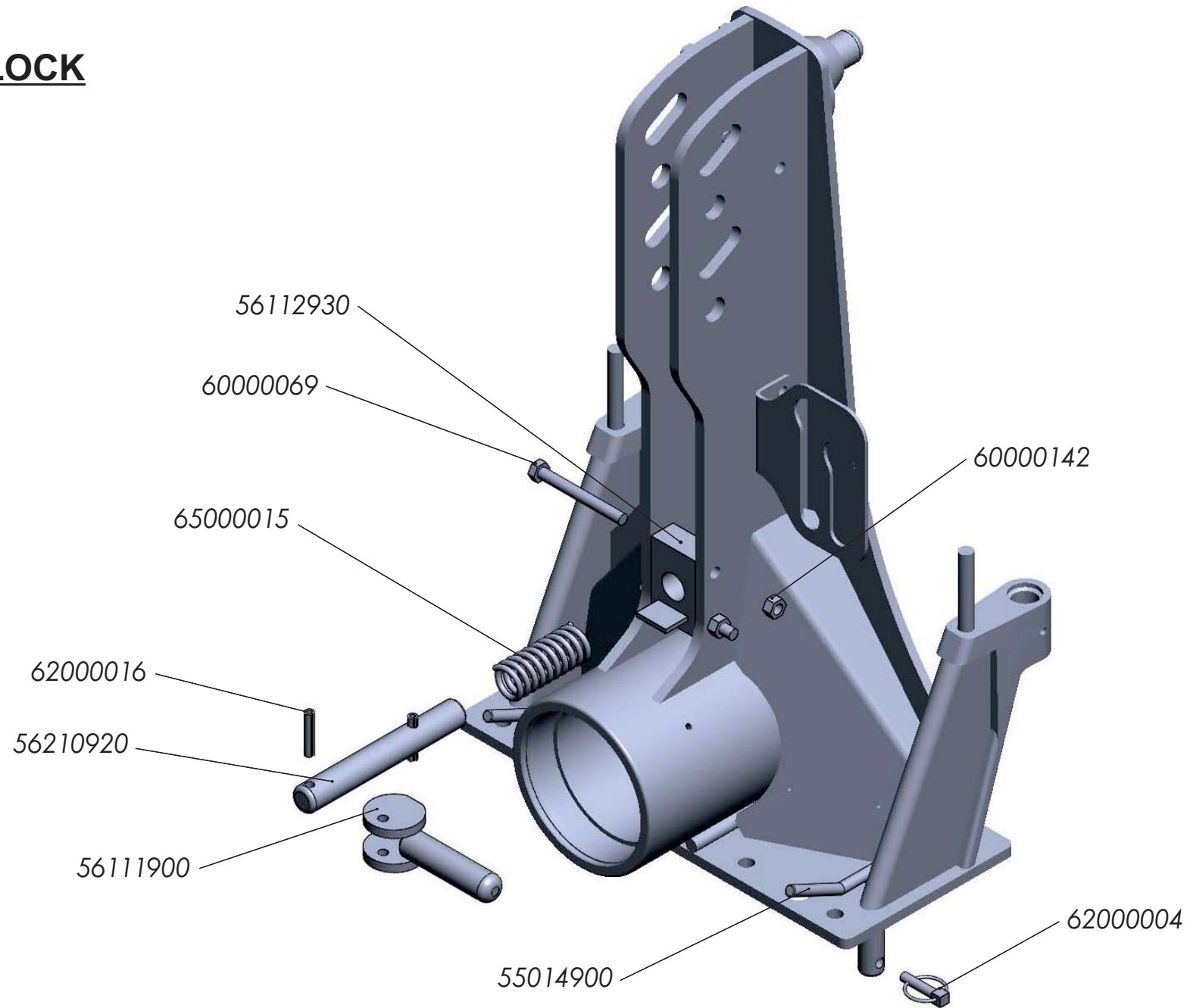

LOCK

Reference	Description
55014900	ROLLER ARM PIN D=25*110 mm
56111900	LOCK
56112930	SUPP. LOCK (C-120/150)
56210920	LOCKING PIN D=29,5*214 mm (D/03)
60000069	BOLT D-931 12*110 8.8 ZINC
60000142	SELF LOCK NUT D-980 12 8.8 ZINC
62000004	RING SPLIT PIN 10 ZINC
62000016	ELASTIC PIN D-1481 10*50 ZINC
65000015	COMPRESSION CYLINDER SPRING 110*40*5 ZINC

DOUBLE WHEEL

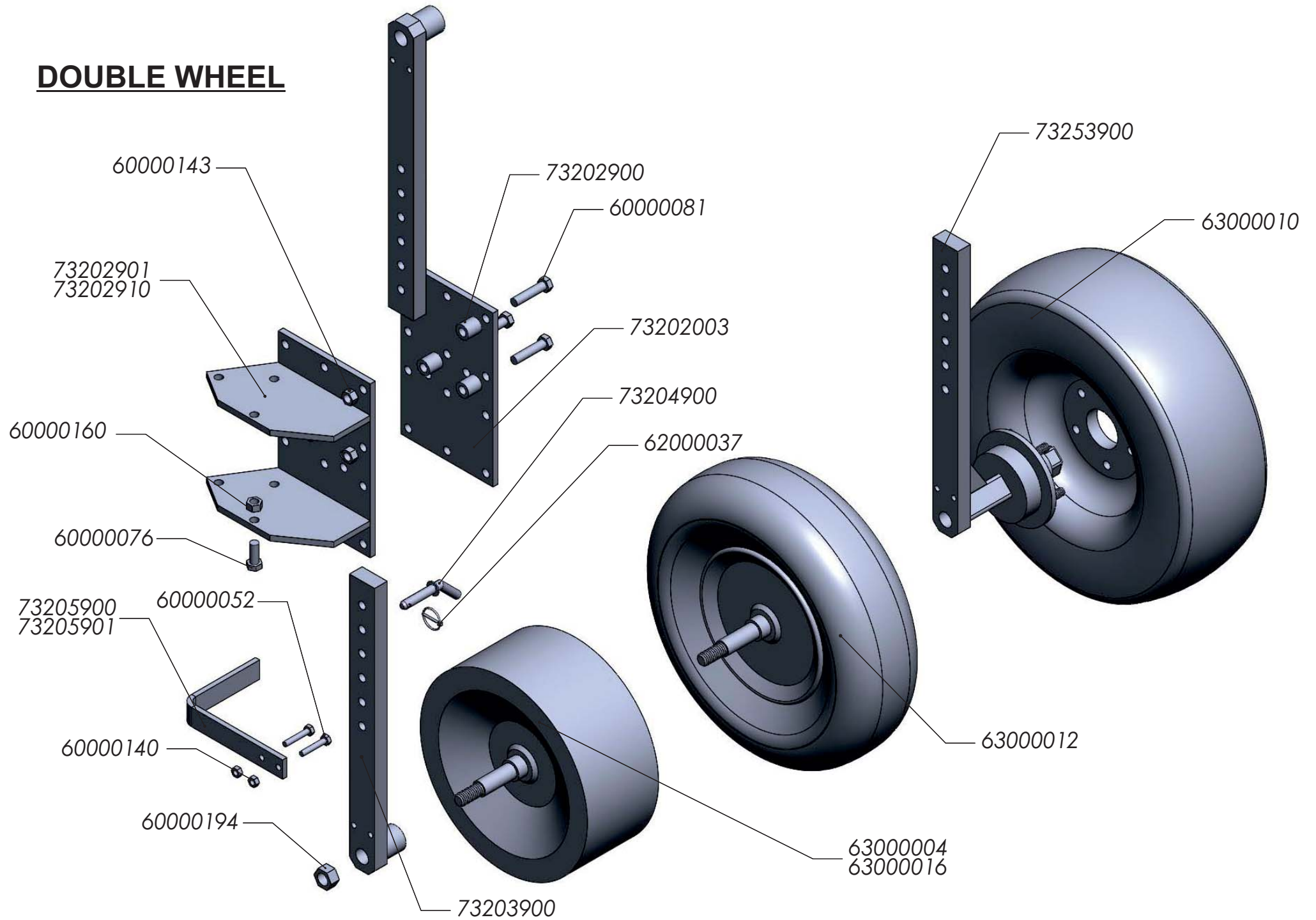

DOUBLE WHEEL

Reference	Description
60000052	BOLT D-931 10*55 10.9 ZINC
60000076	BOLT D-933 16*40 8.8 ZINC
60000081	BOLT D-931 16*70 8.8 ZINC
60000140	SELF LOCK. NUT D-980 10 8.8 ZINC
60000143	SELF LOCK NUT D-980 16 8.8 ZINC
60000160	NUT D-934 16 8.8 ZINC
60000194	SELF LOCK. NUT D-980 24/200 8.8
62000037	RING SPLIT 4,5 ZINC
63000004	METAL WHEEL 400*170*3 RAL-3001
63000010	RUBBER WHEEL 200/60*14,5"-10PR RAL-6029
63000012	RUBBER WHEEL 6.00*9"-10 PR V50 RAL-6029
63000016	METAL WHEEL 500*180*3 RAL-3001
73202003	SIDE PLATE DOUBLE WHEEL (D/03)
73202900	SPACER DOUB. WHEEL SUPP. BUSH D=30/16,5*31,5 mm
73203900	DOUBLE METAL WHEEL ARM
73204900	ADJUST. PIN D=16*150 mm DOUBLE WHEEL
73205900	DOUBLE WHEEL SCRAPER
73205901	KNIFE DOUBLE WHEEL (5)
73202901	DOUBLE WHEEL BRACKET SL/LV (D/04)
73202910	DOUBLE WHEEL BRACKET LV (D/04)
73253900	DOUBLE RUBBER WHEEL ARM (608*205)

OSCIL. WHEEL MF / LN

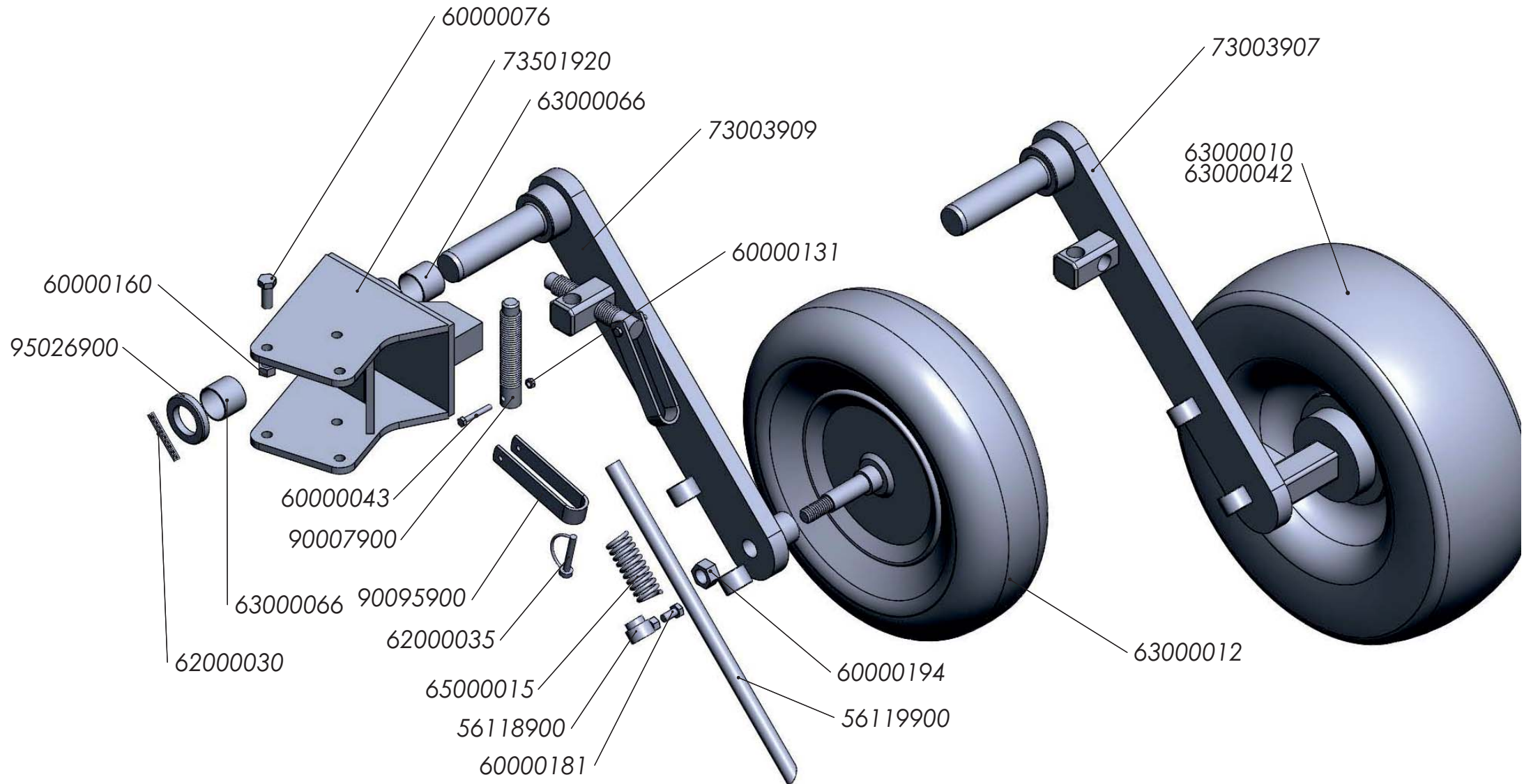

OSCIL. WHEEL MF / LN

Reference	Description
53000004	GREASER MT-503 8*125 D-71412
56118900	ADV.TRANSPORT WHEEL STICK LOCK
56119900	ADV.TRANSPORT WHEEL STICK
60000043	BOLT D-931 8*55 8.8 ZINC
60000076	BOLT D-933 16*40 8.8 ZINC
60000131	SELF LOCKING NUT D-980 8 8.8 ZINC
60000160	NUT D-934 16 8.8 ZINC
60000181	BOLT D-933/912 12*25 8.8 ZINC
62000013	ELASTIC PIN D-1481 8*60 ZINC
62000035	PIN WITH ARC D=10*60 mm ZINC
63000010	RUBBER WHEEL 200/60*14,5"-10PR RAL-6029
63000012	RUBBER WHEEL 6.00*9"-10 PR V50 RAL-6029
63000042	RUBBER WHEEL 250/65*14,5"-12PR RAL-6029
65000015	COMPRESSION CYLINDER SPRING 110*40*5 ZINC
73002900	WASHER ADVANCED WHEEL
73003907	OSCIL RUBBER WHEEL ARM MF/LN (608*205/685*260)
73003909	OSCIL MET/RUBBER WHEEL ARM MF/LN
73501920	OSCIL WHEEL SUPPORT MF/LN
90007900	STOP TURNBUCKLE 185 mm
90095900	STOP BRACELET ZINC

ADVANCED CONTROL WHEEL "L"

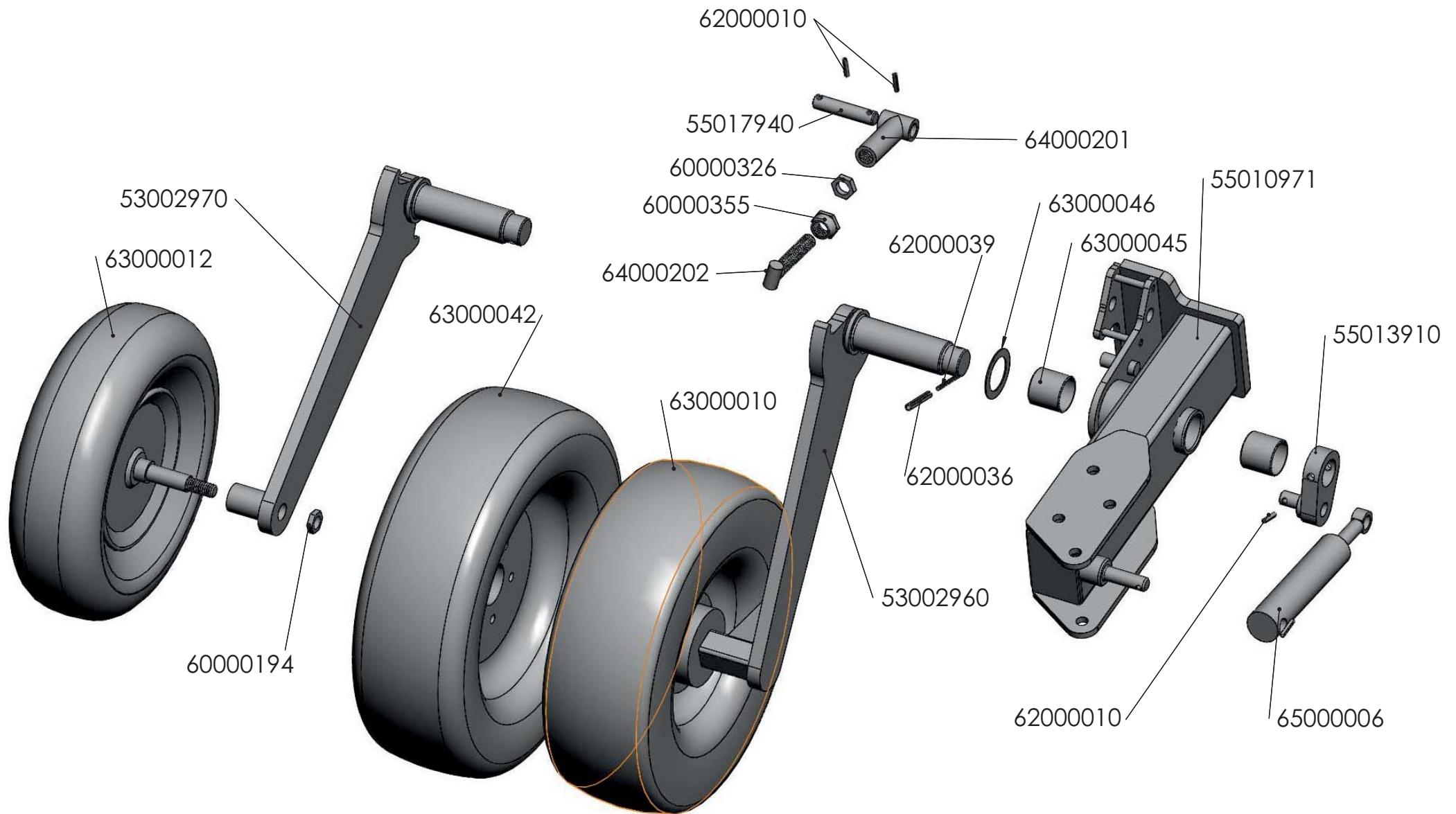

ADVANCED CONTROL WHEEL “L”

Reference	Description
53002960	ARM RUBBER AVZD WHEEL (608*205/685*260)
53002970	ARM MET./RUBB. WHEEL
55010971	AVZD WHEEL SUPPORT L (D/13)
55013910	C/T WHEEL LOCK (D/02)
55017940	TRANSPORT WHEEL STOP PIN D=25*116 mm
60000194	SELF LOCK. NUT D-980 24/200 8.8
60000326	LOW NUT D-936 30/200 8.8 ZINC
60000355	STOP NUT TURNOVER 30/200 8.8 ZINC
62000010	ELASTIC PIN D-1481 8*40 ZINC
62000036	ELASTIC PIN D-1481 12*80 ZINC
62000039	ELASTIC PIN D-1481 7*80 ZINC
63000010	RUBBER WHEEL 200/60*14,5"-10PR RAL-6029
63000012	RUBBER WHEEL 6.00*9"-10 PR V50 RAL-6029
63000042	RUBBER WHEEL 250/65*14,5"-12PR RAL-6029
63000045	BUSH PAP 6060 P10
63000046	DISC PAW 62 P10
64000201	DEPTH STOP SUPPORT
64000202	WHEEL DEPTH STOP
65000006	DEADENER 25/50/145

ADVANCED CONTROL WHEEL "L"

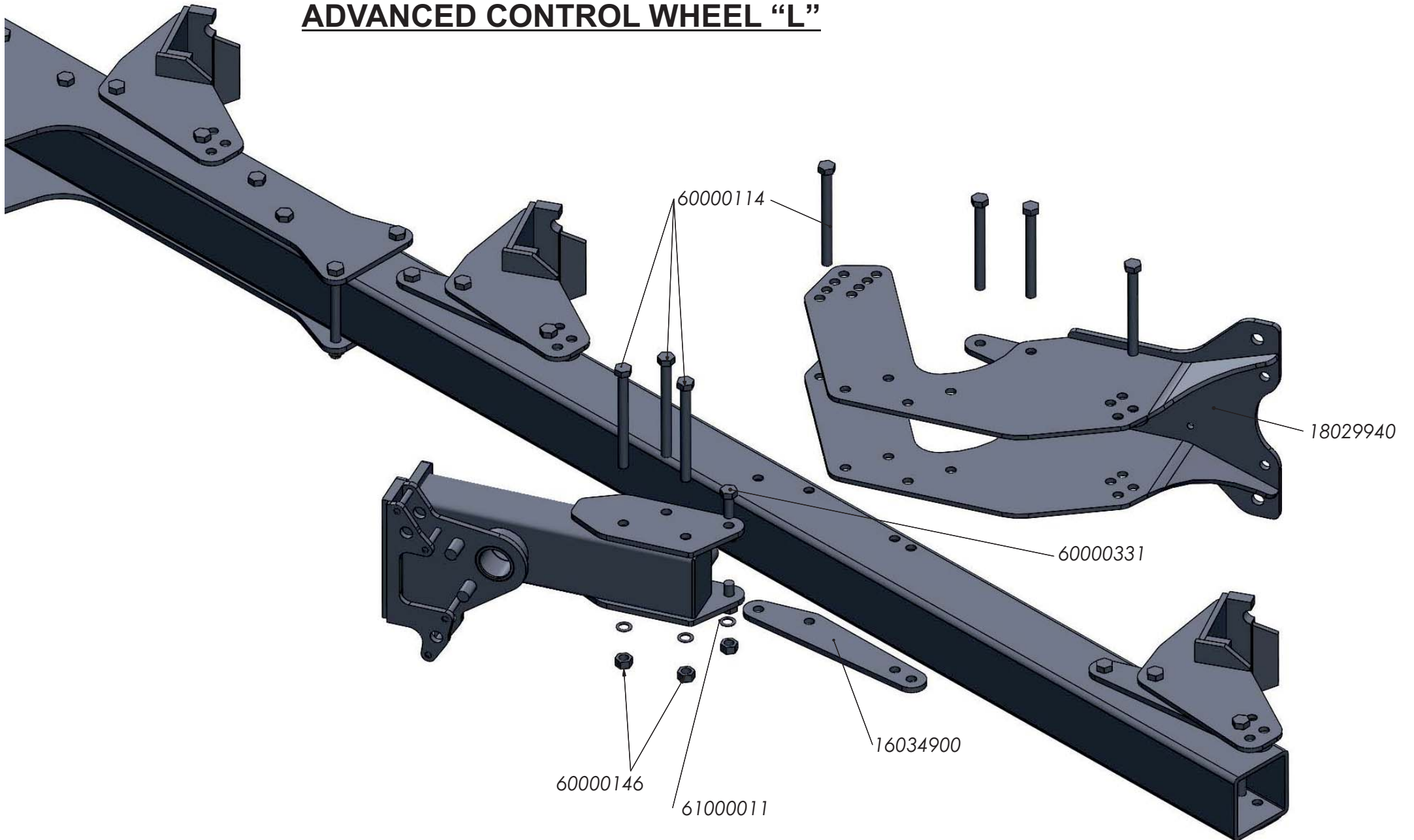

ADVANCED CONTROL WHEEL "L"

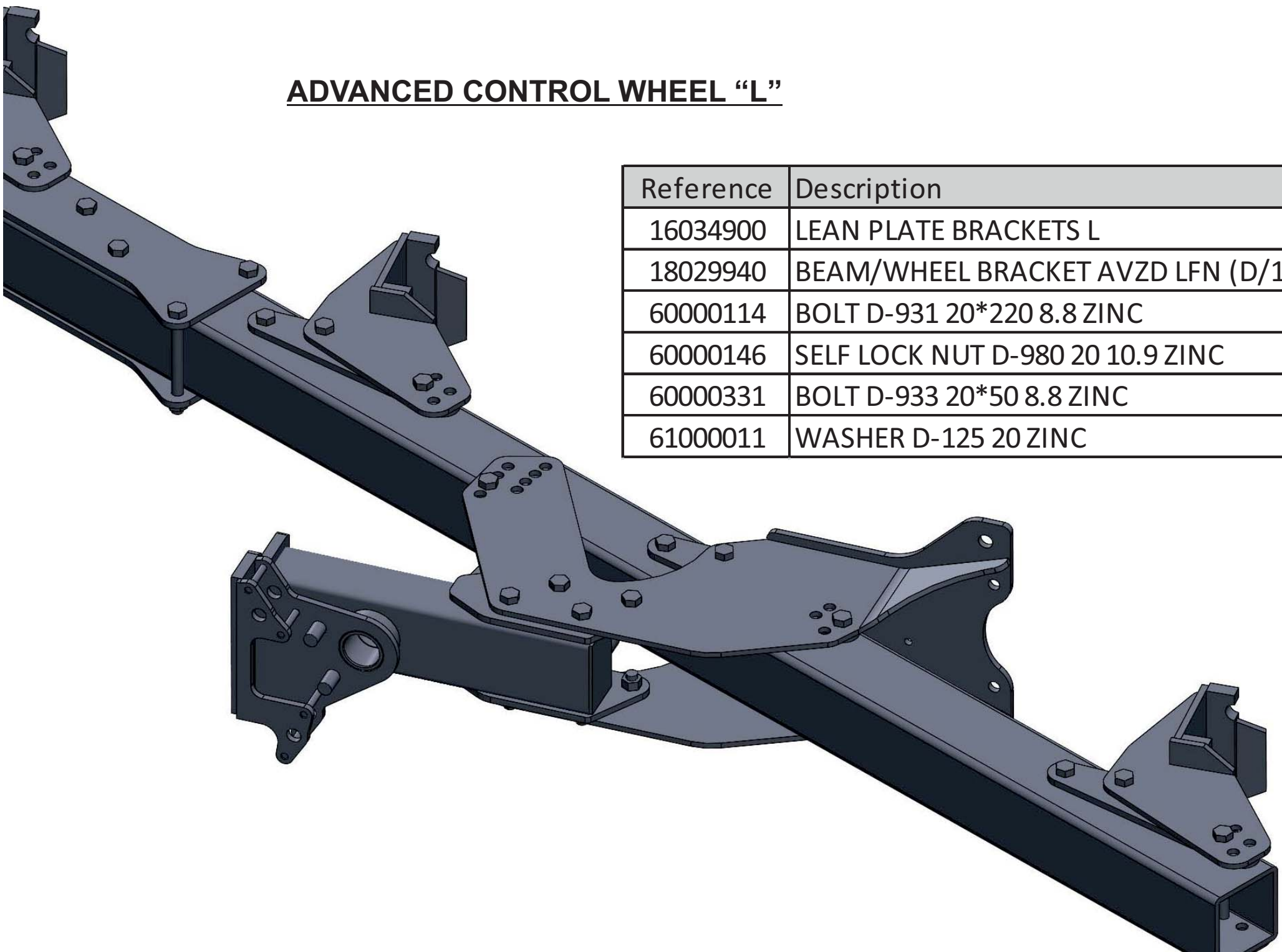

Reference	Description
16034900	LEAN PLATE BRACKETS L
18029940	BEAM/WHEEL BRACKET AVZD LFN (D/13)
60000114	BOLT D-931 20*220 8.8 ZINC
60000146	SELF LOCK NUT D-980 20 10.9 ZINC
60000331	BOLT D-933 20*50 8.8 ZINC
61000011	WASHER D-125 20 ZINC

ADVANCED C/T WHEEL "L"

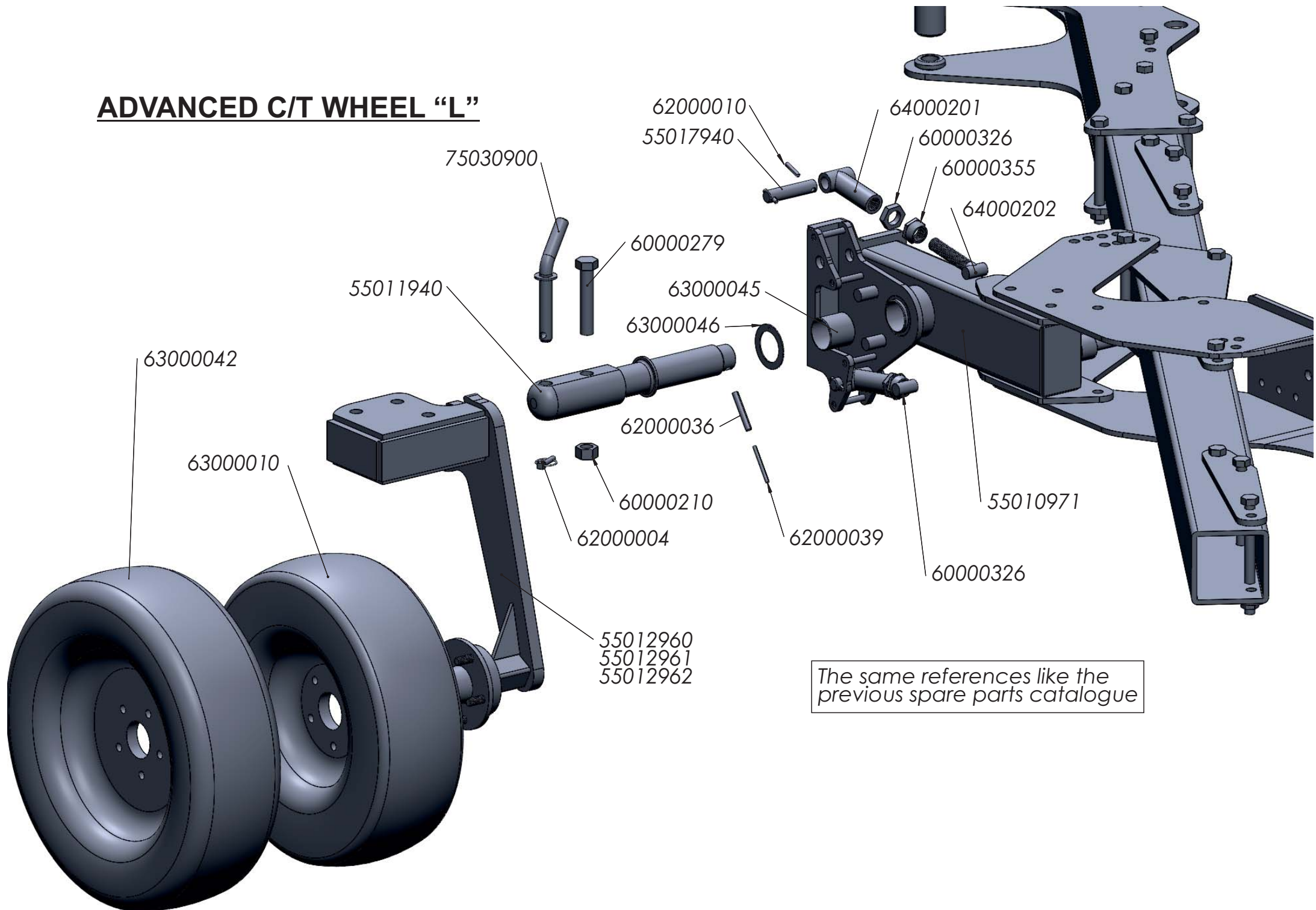

The same references like the previous spare parts catalogue

ADVANCED C/T WHEEL "L"

Reference	Description
55010971	AVZD WHEEL SUPPORT L (D/13)
55011940	SHAFT TRANSPORT WHEEL (D/03)
55012960	C/T ADVANCED WHEEL ARM (608*205/685*260) (D/10)
55012961	C/T ADVANCED WHEEL ARM D/85 (608*205/685*260) (D/10)
55012962	C/T ADVANCED WHEEL ARM MR (608*205/685*260) (D/10)
55017940	TRANSPORT WHEEL STOP PIN D=25*116 mm
60000210	SELF LOCK NUT D-985 1" SAE 8.8
60000279	BOLT 1"*135 SAE 12.9 ZINC
60000326	LOW NUT D-936 30/200 8.8 ZINC
60000355	STOP NUT TURNOVER 30/200 8.8 ZINC
62000004	RING SPLIT PIN 10 ZINC
62000010	ELASTIC PIN D-1481 8*40 ZINC
62000036	ELASTIC PIN D-1481 12*80 ZINC
62000039	ELASTIC PIN D-1481 7*80 ZINC
63000010	RUBBER WHEEL 200/60*14,5"- 10PR RAL-6029
63000042	RUBBER WHEEL 250/65*14,5"- 12PR RAL-6029
63000045	BUSH PAP 6060 P10
63000046	DISC PAW 62 P10
64000201	DEPTH STOP SUPPORT ZINC
64000202	WHEEL DEPTH STOP
75030900	TURNING PIN D=25*255 mm



ovlac

FACTORY AND ADMINISTRATION
OVLAC Fabricación de Maquinaria Agrícola, S.A.
Polígono Industrial, C/ TAF , P-163
34200 – Venta de Baños (Palencia)
SPAIN
Phone: + 34 979 76 10 11
Fax: + 34 979 76 10 22
E-mail: fabricacion@ovlac.com